



MONSTAR LADDER



MONSTAR STEP



2018 PRODUCT GUIDE

MATERIAL HANDLING EQUIPMENT

www.teamsystems.net.au



Team Systems has grown to become Australia's leading manufacturer and importer of Material Handling Equipment.

Team Systems has been at the forefront of continued product development and sourcing of new products from right across the globe.

Our Brands include: Teamstar Trolleys, Teamstep, Rollmasta Conveyor, equip Powered Trolleys, Monstar Ladders, Crane Fork Attachments and Drumtech Drum Handling Equipment, just to name a few.

Team Systems also have a long standing relationship with some of Australia's largest manufacturers like Viscount & Nally Plastics, and Fallshaw Wheels & Castors.

- **National distribution from five branches across Australia.**
- **2000 product lines in stock.**
- **A Streamlined Business Model.**
- **Warehousing & Consolidating orders in China.**
- **Direct manufacturing of products in China for specific customer requirements.**



Team Systems' Values

The values embraced by the people at Team Systems stem from a tradition which has been maintained from the very outset. These values are the key to maintaining successful and transparent relationships which have nurtured long term and mutually prosperous associations.

At Team Systems we expect our people to behave consistently with the following values:

- **Integrity:** Honest, ethical dealings within the letter and spirit of the law
- **Teamwork:** Working towards a common goal in a collaborative, inclusive manner
- **Individual Accountability:** Accepting responsibility, a sense of urgency, an eye for detail and a "can do" attitude
- **Mutual Support and Respect:** Being available, respect for others' opinions, time, feelings and by use of appropriate language
- **Trust and Openness:** Facilitating frequent, transparent two-way communications
- **Courage:** To risk going beyond our comfort zone and to learn from our mistakes
- **Fairness:** Accepting of a difference of opinion and achieving balance and equity in outcomes
- **Uncompromising Standards:** Care for health, safety and the environment as well as living and promoting our values in a culture of continuous improvement and learning.

"Our Goal is to provide Material Handling Equipment and solutions which will allow our customers to operate at the highest level in the Manufacturing, Storage and Distribution of their product."

Shane Poulton *Managing Director*

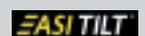

TROLLEYS & CARTS



TeamStar Trolleys 10-12
 Signature Series Trolleys 13-17
 Powered Trolleys & Tables 18
 TeamStar Platform Trolleys 19-20
 Hand Trucks 21-24
 Trolleys & Dollies 25-27
 TeamStar Skates 28-29
 Stainless Steel Trolleys 30

1

CASTORS & WHEELS



TeamStar Castors 32-36
 Fallshaw Pneumatic Wheels 37-38
 Fallshaw Castors 39-41
 Castor Accessories 42

2

LIFTING & HANDLING EQUIPMENT



Pallet Trucks & Scissor Lifts 44-49
 Lifters, Stackers & Handling 50-53
 Conveyor Systems 54-56
 Forklift Attachments 57
 Crane Accessories 58-59
 Packaging, Turntables & Ramps 60-61
 Round & Flat Slings 62-65
 Chain & Lever Blocks & Hoists 66-68
 Lifting Chains, Shackles & Eye Bolts 69-71
 Cargo Handling 72-73

3

DRUM HANDLING & STORAGE



Drumtech Hydraulic Drum Lifters 76
 Drumtech Drum Lifters & Carriers 77-78
 Bulk Drum Storage Systems 79
 Bund Covers, Drum Storage Systems 80

4

SAFETY EQUIPMENT & SIGNAGE



Workplace Safety, Convex Mirrors 82-83
 Portable Barriers 84
 Spill Kits 85
 Gates, Guard Rails & Bollards 86-87
 Floor Matting 88-89
 Dangerous Goods Storage 90-91
 Safety Signs & Tags 92-93
 Impact Protection Bumpers 94

5

LADDERS & ACCESS EQUIPMENT



Work Platforms 96
 TeamSteps 97
 Monstar Steps & Ladders 98-101
 Platform Ladders 102-104
 Double Sided & Extension Ladders 105
 Mobile Platforms 106-107
 Mezzanine Access & Lifts 108

6

PLASTICS & SHELVING



Stack & Nest Containers 110-114
 Ventilated Crates, Buckets & Bins 115-116
 Bulk Bins & Pallets 117
 Storage Containers 118-119
 Rotationally Moulded Bins & Tanks 120-121
 Wheelie Bins, Work Benches & Storage 122-123
 Longspan Shelving & Lockers 124-125

7

TEAM SYSTEMS HISTORICAL TIMELINE

DANDENONG - VICTORIA

**CLAREDALE ROAD
DANDENONG**



Our first location was a small factory at 34 Claredale Road Dandenong Victoria.



Team Systems started as a Steel Fabricator/Manufacturer of Trolleys and Stillages to the manufacturing, food and nursery industry.

DANDENONG - VICTORIA

**CHELTHENHAM ROAD
DANDENONG**



With a business model aimed at Corporate Australia Team Systems receives work from large companies including Coca Cola, United Energy, Spotlight Stores and RACV just to name a few.



**TEAMSTEP
DEVELOPMENT**



In 1998 Team Systems develops the Teamstep Mobile Step Stool. This is the first in our range of Moulded Steps and Roto Moulded Products.



FIRST SHOWROOM



1994

Team Systems was formed in 1994 by Shane and Mevice Poulton (Current Owners) and Darren Calder.



1995

In 1995 Team Systems moved to 35 Amberley Crescent Dandenong Victoria.



Shortly after Team Systems found the need to create its own brand of Trolleys 'Teamstar Trolleys.' This helped develop a sustainable business with better cash flow and better margins.

**AMBERLEY CRESCENT
DANDENONG**



1997

In 1997 Team Systems relocates to far bigger premises with a Showroom fronting Cheltenham Road in Dandenong and a Manufacturing facility directly behind it in Mills Road Dandenong Victoria.

**MILLS ROAD
MANUFACTURING**



1998



**ROBOTIC WELDING
INTRODUCED**



Robotic Welding introduced into the manufacturing process.

DANDENONG SOUTH - VICTORIA

**DANDENONG SOUTH
SHOWROOM/WAREHOUSE**



CAMPBELLFIELD - VICTORIA

**CAMPBELLFIELD
WAREHOUSE**



In October 2004 Team Systems existing premises is compulsory acquired by Vic Roads and Team Systems purchases and relocates and to its own brand new premises.

In 2006 Ray Cieri commences as State Sales Manager and Team Systems opens its first branch located in Campbellfield Victoria.

**AQUISITION
NUPLAS PLASTICS**



In 2002 Team Systems purchases Nuplas Plastics (Logo) and commences importing products from China and Taiwan.



2000

2002

2004

2006

In 2000 Team Systems moves to Robotic Welding and also wins a major tender to manufacture Bar Code Sorter Racks for Australia Post.

Major tender won from Australia Post to manufacture Bar Code Sorter Racks.

Opportunity arises to begin directly importing specialised products from China & Taiwan.

Product Range and Area Distribution expands with the opening of the first Campbellfield Warehouse.

MAJOR TENDER WON



**DIRECT IMPORTING FROM
CHINA & TAIWAN COMMENCES**



TEAM SYSTEMS HISTORICAL TIMELINE



In 2009 Shane Poulton purchases Ideal Wire in Perth from our long standing distributor Eric Smith. We change the name to Ideal Systems (W.A) Pty Ltd and relocates to a company owned premises at 211 Bannister Road Canning Vale Western Australia.



In 2010 Team Systems moves the Campbellfield Branch to larger premises at 1497 Hume Highway Campbellfield Victoria.

BRISBANE BRANCH OPERATES FROM 3PL WAREHOUSE DISTRIBUTION



In 2011 Team Systems opens the Brisbane branch from a 3PL Warehouse and in 2012 purchases a new building to operate and grow the Queensland market.



In October 2014 Team Systems purchases Technicaids Pty Ltd. A Perth based Material Handling Company trading since 1969 and amalgamates it with Ideal Systems in Perth Western Australia.

2009

2010

2011

2012

2013



Branding Evolution

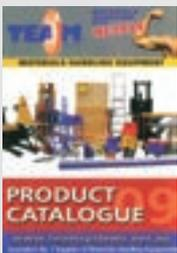

Branding Evolution



From 2011 to 2014 Team Systems continues to grow its international contacts with various distributorships and agreements throughout China, Indonesia, Taiwan and Thailand strengthening its position as a premium Material Handling business. During this period Team Systems completes a number of larger custom made projects with its partners in China delivery new solutions in the logistics industry.



Branding Evolution



Localised themed marketing campaigns to grows product sales & help promote new warehouse openings.



New Website Launch



In November 2014 Shane Poulton purchases a new Industrial Site at Logis Estate Dandenong South Victoria ready for development of our new Head Office and Warehouse with over 2600m2 of storage space.

In October 2015, Team Systems opens up NSW Sales Office and Warehouse in Wetherill Park bridging a National Distribution Point across Australia.

In 2016, Team Systems relocates to New Head Office/Warehouse Building in Logis Boulevard, Dandenong South Victoria.

In 2016, Team Systems purchases new building in Campbellfield and relocates existing Campbellfield Showroom to new premises.



In 2016 Team Systems purchases AUSTEC Trolleys.

2014

2015

2016

2017

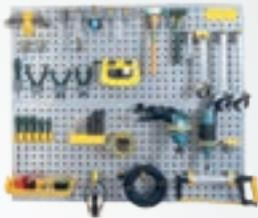

New Product Range continues to be added to inventory to meet growing market demand.

Complete redesign of Corporate Branding & Company Logo.



TEAM SYSTEMS CELEBRATES MILESTONE '20 YEARS IN BUSINESS' 1994 - 2014



NEW DIRECTION BEGINS NEW LOGO & BRANDING

TEAM SYSTEMS PRIVATE BRANDS



Visit Team Systems Web Site

On our new web site you can access information on Team products and a whole lot more; news from Team product updates and handy tips. You'll also find the latest information on our Team products.

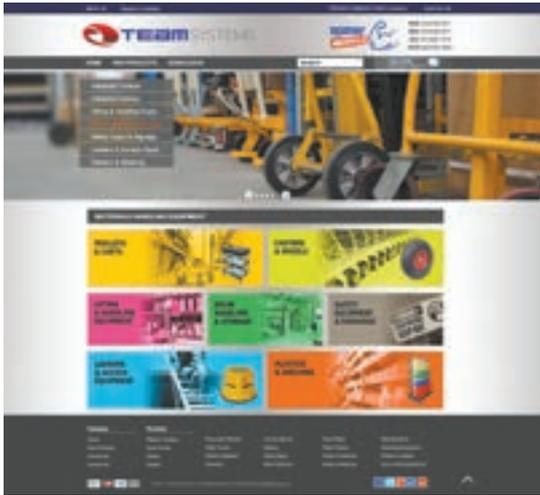

- Quick Links to each category product



- Order online or make an enquiry

- Technical information on every product in every category

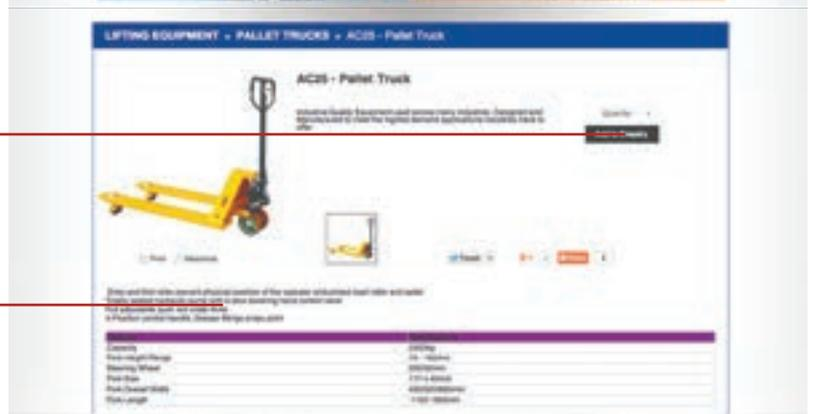

TROLLEYS & CARTS



TeamStar Trolleys	10-12
Signature Series Trolleys	13-17
Powered Trolleys & Tables	18
TeamStar Platform Trolleys	19-20
Hand Trucks	21-24
Trolleys & Dollies	25-27
TeamStar Skates	28-29
Stainless Steel Trolleys	30

TeamStar - The Top Choice in Trolleys

Teamstar Trolleys are a fully welded construction and the Australian design is a winner with our local and national market. Various accessories such as clip boards and parts boxes are also available. (See page 11)

- Some of the many features include:
- 1 Year Frame Warranty
 - Durable long lasting Powder Coated Finish
 - Castor Mounting Plates for versatility
 - Ability to customise on medium and large size orders
 - Standard with 2 Swivel & 2 Rigid Castors



TS1A Flatbed Trolley
High Quality Heavy Duty.

Size	Handle Height	Load Capacity	Wheel Diameter
900 x 600mm	920mm	340kg	100mm



TS3A 3 Tier Steel Trolley
High Quality. Australian Design.

Size	Handle Height	Load Capacity	Wheel Diameter
900 x 600mm	920mm	340kg	100mm



TS1F Full Mesh Trolley
Includes Fold Down Gate. Australian Design.

Size	Handle Height	Load Capacity	Wheel Diameter
900 x 600mm	920mm	340kg	100mm



TS2A 2 Tier Steel Trolley
Non-Slip Industrial Mat. Australian Design.

Size	Handle Height	Load Capacity	Wheel Diameter
900 x 600mm	920mm	340kg	100mm



TS2B Half Basket Trolley
Australian Design.

Size	Handle Height	Load Capacity	Wheel Diameter
900 x 600mm	920mm	340kg	100mm



TS4B 4 Tub Steel Trolley
Great for Picking Orders. Two types of crates available - Sold separately
IH048 - 16L 457 x 318 x 168mm
IH042 - 27L 457 x 318 x 260mm
Australian Design.

Size	Handle Height	Load Capacity	Wheel Diameter
990 x 650mm	920mm	340kg	100mm

All Measurements are Length x Width x Height

Team Systems pride themselves on never compromising the quality of product, and all trolleys come with unsurpassed features.

Powder coated with durable non-slip industrial quality vinyl mats or lipped metal surfaces.
Fitted with quality non-marking wheels and castors.

All trolleys come standard with castor mounting plates. Castors are bolted to these castor mounting plates to allow for ease of castor replacement, or to allow for changes to castor arrangement. Available in a large range of models with ability to customise on large orders.



**TS1AXL
Extra Large
Flatbed Trolley**

Very mobile with 6 Heavy Duty Castors. Australian Design. Optional Accessories include Buffers & Locking Castors.

Size	Handle Height	Load Capacity	Wheel Diameter
1200 x 700mm	1050mm	520kg	160mm



**TSOFT
Office File Trolley**

Great for Picking Orders, Mailing & Files.

Size	Handle Height	Load Capacity	Wheel Diameter
650 x 380mm	930mm	220kg	100mm



**TS1B
Stock
Picking
Trolley**

Options: Clipboard. Utility Bin. Suits Nally Crate IH060, IH051 & IH078 (Sold Separately).

TS1B with Heavy Duty Clipboard/Handle version.

Model	Size	Handle Height	Load Capacity	Wheel Diameter
TS1B	900 x 420mm	1010mm	220kg	100mm



**TSMY
Stock Picking Trolley**

Suits Nally Crate IH060, IH051 & IH078 (Sold Separately).

Size	Handle Height	Load Capacity	Wheel Diameter
900 x 420mm	930mm	220kg	100mm



**TS1BD
Double Tub
Stock Picking Trolley**

Australian Made. Suits Nally Crate IH060, IH051 & IH078 (Sold Separately).

Size	Handle Height	Load Capacity	Wheel Diameter
950 x 420mm	1000mm	220kg	125mm

All Measurements are Length x Width x Height

TROLLEY ACCESSORIES



Team Systems can also supply a number of useful accessories to suit all our trolleys.

TSCLIPBOARD
Optional Clipboard Clamps onto all trolleys. Powdercoated Silver Bull Clip & Pen Rack.

TSOPH
Optional Parts Tray Holder.

IH077
Optional Parts Tray.

High quality imported trolleys with reinforced steel platform deck non-slip surface, plastic bumper prevents scratching and dents to doors, walls and furniture.



Folding Flatbed Trolley
TSS11 Small
TSL11 Large

Quick Release Handle.
 Folds for Easy Storage.
 1000mm Handle Height
 to suit Australian market.

Model	Size	Handle Height	Load Capacity	Wheel Diameter
TSS11	740 x 480mm	1000mm	150kg	100mm
TSL11	890 x 600mm	1000mm	250kg	125mm



TSS22
2 Tier Pressed
Metal Trolley

1000mm Handle Height
 to suit Australian market.

Model	Size	Handle Height	Load Capacity	Wheel Diameter
TSS22	740 x 480mm	1000mm	150kg	100mm



TSS32
3 Tier Pressed
Metal Trolley

Superior Quality Wheels.

Model	Size	Handle Height	Load Capacity	Wheel Diameter
TSS32	740 x 480mm	1000mm	150kg	100mm



TSXL12
Pressed Metal Trolley

Huge Deck Area.

Size	Handle Height	Load Capacity	Wheel Diameter
1160 x 760mm	1000mm	300kg	160mm



TSQ25B
2 Tier
Lipped Trolley

Fully Imported.

Size	Handle Height	Load Capacity	Wheel Diameter
1000 x 700mm	980mm	250kg	125mm



GT500S/GT600S
Tubular Deck Trolley

Galvanised Finish.
 Suitable for Supermarket & Warehouse use.

Model	Dimensions
GT600S	1200 x 600 x 950mm

All Measurements are Length x Width x Height



**HS808E/HS808LE
Double Deck
Service Cart**

Double Handles.
Reinforced Tray.
2 Brake & 2 Swivel Castors.

Model	Size	Handle Height	Load Capacity	Wheel Diameter
HS808E	850 x 480mm	950mm	250kg	100mm
HS808LE	1100 x 520mm	950mm	250kg	100mm



**HS808A/HS808LA
Triple Deck Service Cart**

Double Handles.
Reinforced Tray.
2 Brake & 2 Swivel Castors.

Model	Size	Handle Height	Load Capacity	Wheel Diameter
HS808A	850 x 480mm	1000mm	250kg	100mm
HS808LA	1100 x 520mm	1020mm	250kg	100mm



**HS808LI
Quad Deck
Service Cart**

Double Handles.
Reinforced Tray.
2 Brake & 2 Swivel Castors.

Model	Size	Handle Height	Load Capacity	Wheel Diameter
HS808LI	1100 x 520mm	1080mm	250kg	100mm



**HS808LEA
Double Deck
Service Cart**

3 Side Panels.
Double Handles.
Reinforced Tray.
2 Brake & 2 Swivel Castors.

Model	Size	Handle Height	Load Capacity	Wheel Diameter
HS808LEA	1100 x 520mm	950mm	250kg	100mm



**HS808C/HS808LC
Triple Deck
Service Cart**

3 Side Panels.
Double Handles.
Reinforced Tray.
2 Brake & 2 Swivel Castors.

Model	Size	Handle Height	Load Capacity	Wheel Diameter
HS808C	850 x 480mm	1000mm	250kg	100mm
HS808LC	1100 x 520mm	1020mm	250kg	100mm



**HS808UT
Tub with Lid**

Suitable for our range of Service Cart Trolleys.

Closed Lid

All Measurements are Length x Width x Height



HS922
Double Deck
Tool Trolley
with Twin Drawers

Double Handles.
Twin Drawers with Ball Bearing Sliders
& Quick-return System.
2 Brake & 2 Swivel Castors.

NOTE: Tools not included

Model	Size	Handle Height	Load Capacity	Wheel Diameter
HS922	850 x 480mm	950mm	250kg	100mm



HS931H
Triple Deck
Tool Trolley
with Drawers

Single Handle.
Single Drawer with Ball Bearing Sliders
& Quick-return System.
2 Brake & 2 Swivel Castors.

Model	Size	Handle Height	Load Capacity	Wheel Diameter
HS931H	850 x 480mm	1000mm	250kg	100mm



MT5053
Triple Shelf Strainer Cart

Integrated Frame Handles.
Perforated Top Tray.
2 Brake & 2 Swivel Castors.

Model	Size	Handle Height	Load Capacity	Wheel Diameter
MT5053	550 x 390mm	1160mm	50kg	50mm



MT5054
Quad Shelf Strainer Cart

Integrated Frame Handles.
Perforated Top Tray.
2 Brake & 2 Swivel Castors.

Model	Size	Handle Height	Load Capacity	Wheel Diameter
MT5054	550 x 390mm	1380mm	50kg	50mm



HS808V/HS808U
Utility Bin/Waste Bin

Model	Capacity	Dimensions
HS808V	25 Litres	550 x 390 x 180mm
HS808U	23 Litres	350 x 240 x 470mm

All Measurements are Length x Width x Height



HS808US
Utility Bin/Cutlery Bin

Model	Capacity	Dimensions
HS808US	8 Litres	350 x 240 x 200mm

NOTE: Picture for illustrative purposes only. Trolley not included



HS828D Triple Deck Service Cart

3 Side Panels.
Lockable Front Doors.
Double Handles.
Reinforced Tray.
2 Brake & 2 Swivel Castors.

Model	Size	Handle Height	Load Capacity	Wheel Diameter
HS828D	850 x 480mm	1000mm	250kg	100mm



HS703S Triple Deck Audio Visual Cart

Double Handles.
Vented Lower Side Panels.
2 Brake & 2 Swivel Castors.

NOTE: Computer & Monitor not included

Model	Size	Handle Height	Load Capacity	Wheel Diameter
HS703S	800 x 480mm	1185mm	200kg	100mm



HS931B Triple Deck Utility Service Cart with Tool Board & Drawer

Single Handle.
Single Drawer with Ball Bearing
Sliders & Quick-return System.
Side Can Holder & Side Tray.
2 Brake & 2 Swivel Castors.

NOTE: Tools not included

Model	Size	Handle Height	Load Capacity	Wheel Diameter
HS931B	850 x 480mm	1000mm	250kg	100mm



HS94B Quad Deck Tool Cart with Tool Board

2 Brake & 2 Swivel Castors.
Metal Tool Hooks - Available as Option

NOTE: Tools not included

Model	Size	Handle Height	Load Capacity	Wheel Diameter
HS94B	650 x 410mm	1180mm	200kg	100mm



HS900 Quad Deck Computer Cart

Black Powdercoat Finish
Power Strip Holder.
Lockable Trays.
2 Brake & 2 Swivel Castors.

Model	Size	Load Capacity	Wheel Diameter
HS900	611 x 466/515 x 910mm	70kg	100mm



GT3545/GT3545P Steel Trash Bag Wagon

4 Castor Wheels.
Pedal Option available on GT3545P Model.

Model	Size	Handle Height	Load Capacity	Wheel Diameter
GT3545	450 x 405mm	875mm	60kg	40mm
GT3545P	450 x 405mm	875mm	60kg	40mm

All Measurements are Length x Width x Height

The highest quality imported trolleys. Non-marking PU wheels with precision bearings. 1000mm handle height to suit Australian market. Yellow protectors on all folding handles.



PEDAL BRAKE OPTION
HB MODEL ONLY



HL110/HB210/HB211 Steel Single Deck Trolley

Fixed Handles.
Pedal Brake Option available.

Model	Size	Handle Height	Load Capacity	Wheel Diameter
HL110	745 x 485mm	1000mm	220kg	100mm
HB210	920 x 620mm	1000mm	370kg	125mm
HB211	920 x 620mm	1000mm Fixed Handle	370kg	125mm



PEDAL BRAKE OPTION
HB MODEL ONLY



HL120D/HB220D Steel Double Deck Trolley

Double Handles.
Pedal Brake Option available.

Model	Size	Handle Height	Load Capacity	Wheel Diameter
HL120D	785 x 485mm	1000mm	220kg	100mm
HB220D	965 x 615mm	1000mm	370kg	125mm



PEDAL BRAKE OPTION
HB MODEL ONLY



HL130D/HB230D Steel Triple Deck Trolley

Double Handles.
Pedal Brake Option available.

Model	Size	Handle Height	Load Capacity	Wheel Diameter
HL130D	785 x 485mm	1000mm	220kg	100mm
HB230D	965 x 615mm	1000mm	370kg	125mm



HG511 Steel Single Deck Trolley

Single Fixed Handle.

Model	Size	Handle Height	Load Capacity	Wheel Diameter
HG511	1170 x 765mm	1000mm	650kg	200mm



HL120M/HB220M Steel Double Deck Trolley

Double Fixed Handles.
Zinc Plated Mesh Panels.

Model	Size	Handle Height	Load Capacity	Wheel Diameter
HL120M	820 x 480mm	1010mm	220kg	100mm
HB220M	985 x 610mm	1010mm	370kg	125mm



HB213 Steel Full Mesh Trolley

Double Fixed Handles.
Zinc Plated Mesh Panels.

Model	Size	Handle Height	Load Capacity	Wheel Diameter
HB213	970 x 615mm	1005mm	370kg	125mm
HG313	1225 x 760mm	1010mm	500kg	150mm

All Measurements are Length x Width x Height

www.teamsystems.net.au



GP210
Plastic Single Deck Trolley
Single Foldable Handle.

Model	Size	Handle Height	Load Capacity	Wheel Diameter
GP210	830 x 505mm	1000mm	250kg	125mm



NP220D
Plastic Double Deck Trolley
Double Handles.

Model	Size	Handle Height	Load Capacity	Wheel Diameter
NP220D	845 x 505mm	930mm	250kg	125mm



ACD3048
Aluminium Platform Truck

Ideal for hot, wet applications.
Lightweight, Corrosion-resistant.
High Strength Welded Box Frame.
Corner Sockets allow handles to be used at either or both ends of truck.

Deck Size	Load Capacity	Handle Height	Castors
760 x 1220mm	350kg	940mm	150mm



ST16009F/ST17011F
Stainless Steel Flatbed Trolley
4 Castor Wheels.
Single Folding Handle.

Model	Size	Handle Height	Load Capacity	Wheel Diameter
ST16009F	900 x 600mm	920mm	350kg	100mm
ST17011F	1100 x 700mm	920mm	500kg	200mm



TS26004
Double Deck Tray Trolley
Grade 304 Stainless Steel.
Reversible Stainless Steel Trays.

Model	Size	Handle Height	Load Capacity	Wheel Diameter
TS26004	740 x 400mm	910mm	200kg	100mm



TS36004
Triple Deck Tray Trolley
Grade 304 Stainless Steel.
Reversible Stainless Steel Trays.

Model	Size	Handle Height	Load Capacity	Wheel Diameter
TS36004	740 x 400mm	910mm	200kg	100mm

All Measurements are Length x Width x Height



HG103 Power Cart
Single Handle.
Large Deck Size.

Features	Specifications
Capacity	500kg
Dimensions	1455 x 630 x 1080mm
Deck Size	1280 x 630mm
Motor	400W
Battery	2 x 12V/33Ah
Speed	3-7km/h
Weight	98kg



HG103B Power Cart
Single Handle.
Large Deck Size.

Features	Specifications
Capacity	500kg
Dimensions	1455 x 630 x 1080mm
Deck Size	1280 x 630mm
Motor	400W
Battery	2 x 12V/33Ah
Speed	3-7km/h
Weight	98kg



HG105 Power Cart with Cage
Single Handle.
Large Deck Size.

Features	Specifications
Capacity	500kg
Dimensions	1455 x 630 x 1080mm
Deck Size	1280 x 630mm
Motor	400W
Battery	2 x 12V/33Ah
Speed	3-7km/h
Weight	113kg



HG109 Power Cart with Electric Lift & Drive

Features	Specifications
Capacity	400kg
Dimensions	1240 x 600 x 1100mm
Table Height Range (Min - Max)	430 - 900mm
Deck Size	1000 x 600mm
Motor (Lifting & Driving)	400W
Battery	2 x 12V/33Ah
Weight	180kg



HG116 Power Cart with Electric Lift & Drive

Features	Specifications
Capacity	400kg
Dimensions	1340 x 600 x 1100mm
Table Height Range (Min - Max)	430 - 1600mm
Deck Size	1100 x 600mm
Motor (Lifting/Driving)	800W/400W
Battery	2 x 12V/33Ah
Weight	234kg



HG116B Power Cart with Electric Lift & Drive

Features	Specifications
Capacity	400kg
Dimensions	1340 x 600 x 1100mm
Table Height Range (Min - Max)	430 - 1600mm
Deck Size	1100 x 600mm
Motor (Lifting/Driving)	800W/400W
Battery	2 x 12V/33Ah
Weight	234kg

All Measurements are Length x Width x Height

www.teamsystems.net.au

Constructed from 1.6mm galvanised steel sheet for strength and durability, the flat deck and clean lines makes it look good and allows small items to be carried loose on the trolley.

Fitted with 200mm fixed centre wheels and 125mm swivel castors to each corner (with this design there is a slight rock from end to end built into the trolley to ensure that the centre wheels are always in contact with the ground). This provides a low push effort and good carrying capacity due to the large centre wheels as well as excellent manoeuvrability because of the swivel castors.



**HTS500S/HTS600S
Single Deck 6 Wheel Trolley**

Galvanised Finish.
Rust Proof.
Ideal for use in Coolrooms & Refrigerated Areas.
Supermarkets - Greengrocers.

Model	Deck Type	Load Capacity	Dimensions
HTS500S	Single	450kg	990 x 460 x 950mm
HTS600S	Single	450kg	1140 x 565 x 950mm



**HTS500D/HTS600D
Twin Deck 6 Wheel Trolley**

Galvanised Finish.
Rust Proof.
Ideal for use in Coolrooms & Refrigerated Areas.
Supermarkets - Greengrocers.

Model	Deck Type	Load Capacity	Dimensions
HTS500D	Double	225kg per Deck	990 x 460 x 950mm
HTS600D	Double	220kg per Deck	1140 x 565 x 950mm



**HTD800S2
6 Wheel Furniture & Bulky Items Trolley**

Long Rail Handle either side to contain long & bulky items.
Galvanised Finish.
Rust Proof.
Ideal for use in Coolrooms & Refrigerated Areas.
Also suitable for Removalists & Furniture Stores.

Model	Deck Type	Load Capacity	Dimensions
HTD800S2	Single	450kg	1140 x 800 x 950mm



All Measurements are Length x Width x Height



**BT200/BT400
Single Deck Carton Trolley**

All Welded Construction.
Shelf Clearance 350mm between.
Vertical Push/Pull Handles.

Model	Deck Height	Castors	Dimensions
BT200	180mm	4 x 100mm & 2 x 200mm	1200 x 400 x 1550mm
BT400	180mm	4 x 100mm & 2 x 200mm	1520 x 400 x 1550mm



**SW078BG
Heavy Duty
Platform Trolley**

Large Deck with Removable
Vertical Supports.
Powder Coated Finish.
960mm Handle Height.

Deck Size	Load Capacity	Castors
1372 x 685mm	560kg	125 x 35mm Blue Rubber



**4ZJ28
Heavy Duty
Panel Cart**

Sturdy Solid Base.
Removable Vertical Supports.

Deck Size	Load Capacity	Castors
915 x 750mm	1800kg	125 x 50mm Polyurethane



**SW078
Heavy Duty
Platform Trolley**

Large Deck with Removable Handle.
Also Available in Double Handle.
Powder Coated Finish.
960mm Handle Height.

Deck Size	Load Capacity	Castors
1372 x 685mm	560kg	125 x 35mm Blue Rubber



TPR500

Suitable to carry Timber,
Plaster, Doors etc.

Deck Size	Load Capacity	Castors
1200 x 580 x 1180mm	500kg	150mm



**SNPT5
Steel Nesting
Platform Trolley**

Powder Coated Finish.
960mm Handle Height.

Deck Size	Load Capacity	Castors
1372 x 685mm	800kg	150mm

All Measurements are Length x Width x Height

www.teamsystems.net.au

GENERAL



TSHT1A
General Duty Trolley

1.6mm Tubular Frame.
4mm Base Plate.
Solid Axles.
High Quality Wheels.

Toe Plate	Handle Height	Load Capacity	Wheel Diameter
430 x 250mm	1170mm	180kg	200mm

P HANDLE MODEL ALSO AVAILABLE

GENERAL



TSHT3A
All Purpose Trolley

Puncture Proof Wheels.
1.6mm Tubular Frame.
4mm Base Plate.
Solid Axles.

Toe Plate	Handle Height	Load Capacity	Wheel Diameter
430 x 250mm	1255mm	200kg	250mm Pneumatic

SPECIALIST



TSHTMP
Multi Purpose Trolley

Puncture Proof Wheels.
Suits 200 Litre (44 Gallon) Drums.

Toe Plate	Handle Height	Load Capacity	Wheel Diameter
455 x 195mm	1235mm	200kg	250mm Pneumatic

SPECIALIST



Lean Back Design allows stacked trolley to stand upright on its own.



TSHTSB
Carton Trolley

Puncture Proof Wheels.
Easy Lean Back Design.
Great for heavy cartons stacked to the top.

Toe Plate	Handle Height	Load Capacity	Wheel Diameter
510 x 250mm	1330mm	200kg	250mm Pneumatic

All Measurements are Length x Width x Height



APPLIANCE



AVAILABLE OPTION
111003B SAFETY STRAP
Suits TeamStar Appliance Trolleys.

TSHT4A
4' Appliance Trolley
Stairclimber Assembly.
1 Year Frame Warranty.



Toe Plate	Handle Height	Load Capacity	Wheel Diameter
455 x 185mm	1235mm	220kg	150mm



APPLIANCE



AVAILABLE OPTION
111003B SAFETY STRAP
Suits TeamStar Appliance Trolleys.

TSHT5A
5' Appliance Trolley
Stairclimber Assembly.
1 Year Frame Warranty.



Toe Plate	Handle Height	Load Capacity	Wheel Diameter
455 x 185mm	1540mm	220kg	150mm



APPLIANCE



AVAILABLE OPTION
111003B SAFETY STRAP
Suits TeamStar Appliance Trolleys.



TSHT4P
4' Appliance Trolley
Puncture Proof Wheels.
1 Year Frame Warranty.



Toe Plate	Handle Height	Load Capacity	Wheel Diameter
455 x 185mm	1235mm	200kg	250mm Pneumatic



APPLIANCE



AVAILABLE OPTION
111003B SAFETY STRAP
Suits TeamStar Appliance Trolleys.



TSHT5P
5' Appliance Trolley
Puncture Proof Wheels.
1 Year Frame Warranty.



Toe Plate	Handle Height	Load Capacity	Wheel Diameter
455 x 185mm	1540mm	200kg	250mm Pneumatic

All Measurements are Length x Width x Height

www.teamsystems.net.au



INDUSTRIAL TROLLEYS

60% less effort to tilt back a fully loaded trolley*
Perfect load balance over wheels with a full load.



The secret is in the axle

Simply tap the axle lock lever with your foot, so the axle can "float" and tilt the trolley backwards. You won't believe heavy loads can feel so light. Axle lock re-engages automatically when the trolley is returned to its upright position.

Baldini Floating Axle™



Customer testimonial

"Easi Tilt Trolleys are a top quality product. All our drivers love them as they make their job so much easier. I can highly recommend them."



**OH&S
AWARD
WINNER**



TOE-TO-TOE

Available as an optional extra.
450 x 450mm.
Extends the base of your trolley to give you a larger surface area carry plate.

BOX 'N' BAG

SF300

Powder Coated RHS & Structural Steel.
1290mm x 370mm Frame Size.
Multi Grip Loop Handle.

The Load Support System provides full height, flat surface RHS frame for secure support of double box stacks. For example, you can carry 13 cartons of beer safely with this trolley instead of 7 cartons with most others. Suitable for heavy loads of boxed & bagged products. e.g. drink products, frozen food, flour, tiles, appliances & furniture.

Load Capacity	Base Plate	Wheel Diameter	Weight
300kg	430 x 240 x 9mm	260mm	22kg

AVAILABLE OPTION PUNCTURE - PROOF WHEELS



TOE-TO-TOE

Available as an optional extra.
450 x 450mm.
Extends the base of your trolley to give you a larger surface area carry plate.

ALL ROUNDER

TH300

Powder Coated Structural Steel.
Ergonomic Hand Grips.
1400mm x 370mm Frame Size.

The Load Support System provides curved support with 60mm set back. Adjustable drum holding hook or optional tub holding hook. When the hook is not required, simply rotate the mounting collar sideways out of the way. Suitable as a Multi Purpose Trolley.

Excellent for heavy drums, barrels, tubs, gas cylinders, garden ornaments, car & truck parts, paint cans, appliances & large boxed goods.

Load Capacity	Base Plate	Wheel Diameter	Weight
300kg	430 x 240 x 9mm	260mm	20kg

AVAILABLE OPTION PUNCTURE - PROOF WHEELS



TOE-TO-TOE

Available as an optional extra.
450 x 450mm.
Extends the base of your trolley to give you a larger surface area carry plate.

SUPER MOVER

DL1600C

Powder Coated Structural Steel.
Two Hand Grip Levels.
1560mm x 430mm Frame Size.

Flat Load Support System Ratchet Strap can be fitted.

Tall & strong trolley suitable for safely moving big fridges, freezers, ATM machines, game machines, stacks of tyres, large hot water cylinders, heavy gas cylinders & furniture.

Load Capacity	Base Plate	Wheel Diameter	Weight
300kg	430 x 240 x 9mm	320mm	28kg

RUXXAC



RUXXAC BUSINESS Folding Trolley

Aluminium Construction.
Made in Europe.

Model	Folded Height	Width	Platform (W x L)	Load Capacity
BUSINESS	685mm	490mm	490 x 250mm	125kg
BUSINESS XL	735mm	490mm	490 x 410mm	125kg

TEAMSTAR
Signature Series



SFT2809/SFT3011 Foldable Hand Truck
Chrome Plated.

Model	Size	Handle Height	Load Capacity	Wheel Diameter
SFT2809	500 x 400mm	930mm	80kg	125mm
SFT3011	510 x 500mm	1000mm	100kg	150mm

AluTruk



ALUTRUKD Aluminium Trolley

Anodised Aluminium Frame with Straight Cross Members.
P-Loop Handle.
Stair Glides with Replaceable Low-Friction Polymer Skid Bars.
Extruded Aluminium Toe-Plate.
Puncture-Proof Tyres.
3-Piece Reinforced Steel Hubs.
Magnesium Axle Brackets.
Solid 16mm Plated Steel Axle Rod.

Toe Plate	Handle Height	Load Capacity	Wheel Diameter
400 x 300mm	1310mm	300kg	260mm

AluTruk



ALUTRUKB Aluminium Trolley

Special, Long Aluminium Frame for tall loads.
P-Loop Handle.
260mm Diameter Balloon Rubber Tyres.
Plastic Hubs.
Magnesium Axle Brackets.

Toe Plate	Handle Height	Load Capacity	Wheel Diameter
400 x 300mm	1600mm	300kg	260mm

AluTruk

EASILY CONVERTS TO A PLATFORM TROLLEY



ALUTRUKC Convertible Aluminium Trolley

Increase Productivity by carrying double the volume.
300kg Load Capacity (Tested In Upright Position).
500kg Load Capacity (Tested In Four-Wheel Mode).
Puncture-Proof Tyres.
High Quality Castors.
Rear Castors Also Available With Brakes.

Toe Plate	Handle Height	Load Capacity	Wheel Diameter
400 x 300mm	1550mm	300kg	260mm

ML1 Material Lifter

Patented Silent Winch.
Swappable Accessories for handling different loads.
Foldable Design folds and unfolds in 30 seconds.
10" Puncture Proof Wheels.



Lift Height	Weight	Platform (W x L)	Load Capacity
1050mm	26.5kg	450 x 450mm	120kg Tray/ 150kg Fork

All Measurements are Length x Width x Height

www.teamsystems.net.au



**TSCST
CHAIR 'STACKER'
Trolley**

Solid Steel Construction.
Ergonomic & Stable.
Safe Handling of Stacker Chairs.
Fits most Chair Types.
Australian Made.

Model	Load Capacity	Dimensions
TSCST	100kg	330 x 450mm (1st Level)



**BT200/BT400
Single Deck Carton Trolley**

All Welded Construction.
Shelf Clearance 350mm between.
Vertical Push/Pull Handles.

Model	Deck Height	Castors	Dimensions
BT200	180mm	4 x 100mm & 2 x 200mm	1200 x 400 x 1550mm
BT400	180mm	4 x 100mm & 2 x 200mm	1520 x 400 x 1550mm



**TSRT - Rotomoulded Tub
TSRT - Trolley**

Suitable for Laundry, Stock Handling & Waste.

BLUE
WHITE

Capacity	Internal Dimensions
400 Litres	1130 x 600 x 600mm



NOTE: Pictured with optional Corflute Top

TSSLB - Spring Loaded Base

Reduce injury by fitting the springloaded base (25, 50 or 100kg).
Fully Automatic Spring Scissor Mechanism. No power required.
Automatically maintains the top load at ideal lifting height.
10kg, 25kg, 50kg or 100kg Springs.
Optional Extra - Corflute Top or Solid Plastic Top - 1095 x 600mm.

Model	Dimensions - Diameter x Height
TSSLB	700 x 400mm



**C009 - Rotomoulded Tub
C009D - Dolly**

Dollies fitted with 100mm Castors.
420kg Capacity Dolly.

420kg CAPACITY
**TUB DOLLY
SOLD SEPARATE**

Model	Type	Load Capacity	Dimensions
C009	Tub	350 Litres	1250 x 760 x 660mm
C009D	Dolly	420kg	1080 x 550mm



**C009 - Rotomoulded Tub
C009T - Trolley**

Ideal for holding Liquids including Linen & Laundry applications.
125mm High Quality Blue Rubber Castors.
420kg Capacity Trolley.

420kg CAPACITY
**TUB TROLLEY
SOLD SEPARATE**

Model	Type	Load Capacity	Dimensions
C009	Tub	350 Litres	1250 x 760 x 660mm
C009T	Trolley	420kg	1250 x 760 x 815mm

All Measurements are Length x Width x Height





TSUPFT2 Upright File Trolley
 Chrome Plated Upright File Trolley with 2 Fold Up Shelves.
 Optional Rain Cover Available.
 3 Tier Shelf.
 Australian Made.

Model	Load Capacity	Dimensions
TSUPFT2	120kg	500 x 465 x 1100mm



CLAXMOBILE Folding Trolley
 The Clever Folding Cart.
 Can be collapsed quickly and easily at the push of a button.
 2 large load platforms for folding plastic boxes or beverage containers.
 Useful features include: a block brake, holding device for boxes, upward folding load platform.
 Made of injection moulded plastic and aluminium for long service.

Box Height	Tray Capacity	Weight	Dimensions
270mm	20kg upper/40kg lower	7kg	890 x 550 x 1030mm



AKH252 Plastic Platform Truck
 Latest Design, Heavy Duty Construction.
 Suitable for Industrial Applications.
 Built in Storage Bin Handles.
 Large, silent, non-marking Castors.

Model	Wheels	Load Capacity	Dimensions
AKH252S	125mm	250kg	790 x 435 x 850mm
AKH252L	125mm	250kg	950 x 650 x 850mm



AKH253 Plastic Platform Truck
 Latest Design, Heavy Duty Construction.
 Suitable for Industrial Applications.
 Built in Storage Bin Handles.
 Large, silent, non-marking Castors.

Model	Wheels	Load Capacity	Dimensions
AKH253S	125mm	250kg	790 x 435 x 850mm
AKH253L	125mm	250kg	950 x 650 x 850mm



Piano Trolley
 Ideal for moving furniture.
 Optional Pneumatic or Solid Wheel Available.

PNEUMATIC, SOLID WHEELS & PUNCTURE PROOF AVAILABLE

Model	Wheels	Load Capacity	Dimensions - Length x Width
TSPTS	200mm Solid	400kg	860 x 500mm
TSPTP	250mm Pneumatic	450kg	860 x 500mm
TSPTPP	250mm Puncture Proof	400kg	860 x 500mm



TSFD Furniture Dolly
 Ideal for moving furniture.
 4 x 100mm Castors.

Model	Load Capacity	Dimensions - Length x Width
TSFD	300kg	550 x 800mm

All Measurements are Length x Width x Height

www.teamsystems.net.au



CUSTOM SIZES AVAILABLE



FDL6040 Dolly
Fully Imported.

Model	Wheels	Load Capacity	Dimensions
FDL-6040	100mm Solid	80kg	605 x 387 x 135mm



SUITS
IH060, IH051,
IH078 & IH315/310
Stack & Nest Tubs



TS10PD Plastic Dolly

Temperature Rating to - 20°C to 60°C.
Food Grade.
Standard colours are Yellow, Blue & White.
Other colours available POA.
Suits Crate IH060, IH051 & IH078 (Sold Separately).



Model	Wheels	Load Capacity	Dimensions
TS10PD	100mm	150kg	620 x 400mm



RM80DY Plastic Dolly

Australian Made.
Standard colour Blue.
Other colours available POA.

SUITS
IH323
Bread Crate

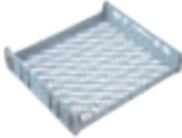

Model	Wheels	Load Capacity	Dimensions
RM80DY	100mm	140kg	620 x 710mm



RM74DY Plastic Dolly

Australian Made.
Standard colour Blue.
Other colours available POA.

SUITS
IH066 Fish Crate



Model	Wheels	Load Capacity	Dimensions
RM74DY	100mm	140kg	710 x 450mm



AKA150 Plastic Dolly

Heavy Duty ABS Construction.

Model	Weight	Wheels	Load Capacity	Dimensions
AKA150	3.8kg	100mm	150kg	620 x 420 x 180mm



AKA251 Plastic Dolly

Heavy Duty ABS Construction.

Model	Weight	Wheels	Load Capacity	Dimensions
AKA251	3.8kg	100mm	150kg	604 x 402 x 162mm



RA480 Interconnecting Plastic Dolly

Reinforced PP Construction.

Model	Weight	Wheels	Load Capacity	Dimensions
RA480	2.3kg	75mm	150kg	480 x 380 x 30mm



RA670 & RA670L Plastic Dolly with Integral Handle Hole

Reinforced PP Construction.
RA670L features a Raised Lip to 3 sides.

Model	Weight	Wheels	Load Capacity	Dimensions
RA670	3.8kg	100mm	300kg	670 x 460 x 145mm
RA670L	3.8kg	100mm	300kg	670 x 460 x 165mm

All Measurements are Length x Width x Height



**TS10CD
Crate Dolly**

4 x 100mm Castors.
Suits Crate IH060, IH051 & IH078 (Sold Separately).

Model	Load Capacity	Dimensions - Length x Width
TS10CD	80kg	600 x 360mm



**SUITS
IH060, IH051,
IH078 & IH315/310
Stack & Nest Tubs**

**TS10PD
Plastic Dolly**

Temperature Rating to - 20°C to 60°C.
Food Grade.

Standard colours are Yellow, Blue & White.
Other colours available POA.

Suits Crate IH060, IH051 & IH078 (Sold Separately).



Model	Wheels	Load Capacity	Dimensions
TS10PD	100mm	150kg	620 x 400mm



**ABD150
Corner Movers**

Pressed Steel Construction.
Low Level Corner Skates to assist
with moving awkward rectangular loads.
Ball Bearing Castors.

Capacity	Load Wheels	Wheel Size	Overall Size	Weight
100kg	3	50 x 20mm	366 x 204 x 85mm	8kg per set 4

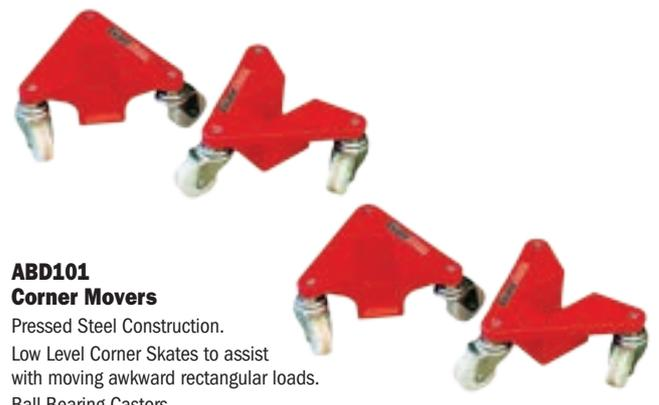

**ABD101
Corner Movers**

Pressed Steel Construction.
Low Level Corner Skates to assist
with moving awkward rectangular loads.
Ball Bearing Castors.

Capacity	Load Wheels	Wheel Size	Overall Size	Weight
100kg	3	50 x 20mm	195 x 165 x 85mm	4.8kg per set 4



**FY02
2 Tonne Skate**

Maintenance Free.
Fitted with a rubber surface to help protect
& stabilise items from moving.

Capacity	Load Wheels	Wheel Size	Skate Size	Weight
2T	2	75mm	270 x 120 x 110	8.4kg

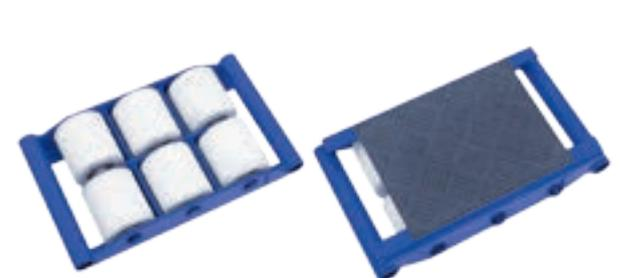

**FW06
6 Tonne Skate**

Stable, Rugged & Low Level Construction.

Capacity	Load Wheels	Wheel Size	Skate Size	Weight
6T	6	75mm	395 x 330 x 101mm	13.8kg

All Measurements are Length x Width x Height

www.teamsystems.net.au



**SFW03
3 Tonne Skate
with Handle**

Incorporates a 1 metre Drawbar
& Platform that swivels on a thrust bearing.

Capacity	Load Wheels	Wheel Size	Skate Size	Weight
3 T	4	75mm	250 x 40 x 950mm	14kg



**FY12
12 Tonne Skate**

Ideal for moving heavy machinery.

Capacity	Load Wheels	Wheel Size	Skate Size	Weight
12 T	8	115 x 60mm	400 x 345 x 145mm	30kg



**CTA4
4 Tonne Skates**

CTAHD - Optional Handle Also Available.

Capacity	Load Wheels	Wheel Size	Skate Size	Weight
CTA4	4	75mm	300 x 222 x 110mm	16kg



**CTA6
6 Tonne Skates**

CTAHD - Optional Handle Also Available.

Capacity	Load Wheels	Wheel Size	Skate Size	Weight
CTA6	6	75mm	400 x 222 x 110mm	23kg



AQR20

Maintenance Free.
Fitted with a rubber surface to help protect & stabilise items from moving.

Capacity	Load Wheels	Wheel Size	Skate Size	Weight
10 T	14	24 x 84mm	267 x 146 x 133mm	17kg



AQR30

Maintenance Free.
Fitted with a rubber surface to help protect & stabilise items from moving.

Capacity	Load Wheels	Wheel Size	Skate Size	Weight
15 T	16	30 x 102mm	324 x 165 x 130mm	21kg

All Measurements are Length x Width x Height



**MAN0287E17TL
1/1 Gastronorm Trolley**

Teamsystems 1/1Gastronorm Trolleys are made to be manoeuvrable and easy to clean.

A 25mm square tube frame and 1.5mm thick tray runners provide uncompromised strength.

Easy to clean Tray Locks.

4 Locking Castors are fitted as standard.

Trolleys are supplied flat packed for ease of handling and cost efficient delivery.

Polished Stainless Steel Finish.

Tray Size	Tray Capacity	Dimensions
1/1 - 530 x 325mm	17 Trays @75mm Centres	410 x 565 x 1700mm



**MAN0287N
2/1 Gastronorm Trolley**

Teamsystems Gastronorm Trolleys are made to handle the tough working environments of Australia's most fast paced kitchens.

A 30mm square tube frame and 1.5mm thick tray runners provide uncompromised strength.

Easy to clean Tray Locks.

4 Locking Castors are fitted as standard.

Trolleys are supplied flat packed for ease of handling and cost efficient delivery.

Polished Stainless Steel Finish.

Tray Size	Tray Capacity	Dimensions
2/1 - 530 x 650mm	18 Trays @75mm Centres	690 x 630 x 1700mm



**MAN0283
Pastry Trolley**

Trolleys are designed to be flat packed for cost efficient delivery and are easily assembled using simple but strong locking crossbars.

Cooling wires are also available, made in either chrome or stainless steel, in a range of sizes and patterns to suit.

OPTIONS AVAILABLE:

Side or End Load.

Full Stainless Steel Construction.

Castors with Brake.

22 Tiers.

Custom Tray Width.

Cooling Wires to suit.

Zinc Plate with Clear Lacquer Finish.

Tray Size	Tray Capacity	Dimensions
735 x 405mm	18 Trays @75mm Centres	760 x 465 x 1650mm



**MAN0281
Breakfast Tray Trolley**

Teamsystems Trolleys are made tough and reliable.

The Breakfast Tray Trolley is made from 25mm square tube and 1.5mm thick tray runners for heavy loads.

Easy to clean Tray Locks.

2 Locking Castors are fitted as standard.

Trolleys are supplied flat packed for ease of handling and cost efficient delivery.

Polished Stainless Steel Finish.

Tray Size	Tray Capacity	Dimensions
2/1 - 530 x 650mm	10 Trays @150mm Centres	590 x tray size x 1768mm

All Measurements are Length x Width x Height

CASTORS & WHEELS



TeamStar Castors	32-36
Fallshaw Pneumatic Wheels	37-38
Fallshaw Castors	39-41
Castor Accessories	42



General Duty/Light Grey Rubber 50kg - 75kg Capacity



- Double Ball Race Head Set.
- Pressed Metal Frame.
- Zinc Plated Corrosion Resistant Frame.
- Axle Sleeve through Wheel.
- TPP Rubber. Suitable for most surfaces.



Bolt Hole Type

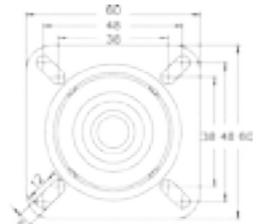

Plate Type



50kg - 75kg CAPACITY		BOLT HOLE - 10mm		MOUNTING PLATE		
Wheel Diameter	Overall Height	Model	Model	Model	Model	Model
50mm (50kg)	69mm	TE11TPP050H	TE11TPP050HB	TE11TPP050S	TE11TPP050SB	TE11TPP050R
75mm (70kg)	100mm	TE11TPP075H	TE11TPP075HB	TE11TPP075S	TE11TPP075SB	TE11TPP075R
100mm (75kg)	125mm	TE11TPP0100H	TE11TPP0100HB	TE11TPP0100S	TE11TPP0100SB	TE11TPP0100R

Industrial Grey Rubber 150kg - 190kg Capacity



- Double Ball Race Head Set.
- Pressed Metal Frame.
- Zinc Plated Corrosion Resistant Frame.
- Precision Ball Bearing.
- TPP Rubber. Suitable for most surfaces.



Bolt Hole Type

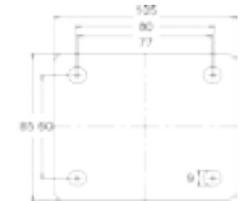

Plate Type



150kg - 190kg CAPACITY		BOLT HOLE - 12mm		MOUNTING PLATE		
Wheel Diameter	Overall Height	Model	Model	Model	Model	Model
80mm (140kg)	108mm	TE21TPB80H	TE21TPB80HB	TE21TPB80S	TE21TPB80SB	TE21TPB80R
100mm (150kg)	128mm	TE21TPB100H	TE21TPB100HB	TE21TPB100S	TE21TPB100SB	TE21TPB100R
125mm (190kg)	155mm	TE21TPB125H	TE21TPB125HB	TE21TPB125S	TE21TPB125SB	TE21TPB125R

Institutional Grey Rubber 150kg - 190kg Capacity



- Double Ball Race Head Set.
- Pressed Metal Frame.
- Zinc Plated Corrosion Resistant Frame.
- Thermo Plastic Rubber.
- Plain Bearing.



Bolt Hole Type



150kg - 190kg CAPACITY		BOLT HOLE - 12mm				
Wheel Diameter	Overall Height	Model	Model			
125mm (190kg)	108mm	TE15TEP125H	TE15TEP125HB			

Stainless Steel Urethane 180kg - 290kg Capacity

- Double Ball Race Head Set.
- Pressed Stainless Steel Metal Frame.
- Stainless Steel Axle Sleeve.
- Nylon Wheel.



Bolt Hole Type

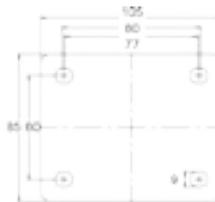

Plate Type A

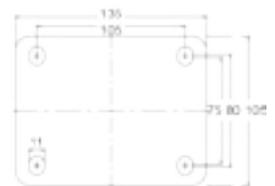

Plate Type B

180kg - 290kg CAPACITY		BOLT HOLE - 12mm		MOUNTING PLATE			
Wheel Diameter	Overall Height	Model	Model	Model	Model	Model	Plate Type
80mm (180kg)	108mm	TE22UNI080H	TE22UNI080HB	TE22UNI080S	TE22UNI080SB	TE22UNI080R	A
100mm (190kg)	128mm	TE22UNI100H	TE22UNI100HB	TE22UNI100S	TE22UNI100SB	TE22UNI100R	A
125mm (270kg)	155mm	TE22UNI125H	TE22UNI125HB	TE22UNI125S	TE22UNI125SB	TE22UNI125R	A

Stainless Steel 180kg - 290kg Capacity

- Double Ball Race Head Set.
- Pressed Stainless Steel Metal Frame.
- Stainless Steel Axle Sleeve.
- Nylon Wheel.



Bolt Hole Type

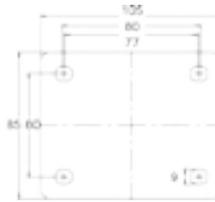

Plate Type A

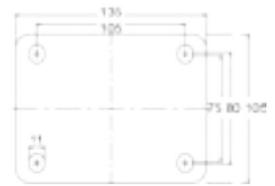

Plate Type B

180kg - 290kg CAPACITY		BOLT HOLE - 12mm		MOUNTING PLATE			
Wheel Diameter	Overall Height	Model	Model	Model	Model	Model	Plate Type
80mm (180kg)	108mm	TE22NNP080H	TE22NNP080HB	TE22NNP080S	TE22NNP080SB	TE22NNP080R	A
100mm (190kg)	128mm	TE22NNP100H	TE22NNP100HB	TE22NNP100S	TE22NNP100SB	TE22NNP100R	A
125mm (270kg)	155mm	TE22NNP125H	TE22NNP125HB	TE22NNP125S	TE22NNP125SB	TE22NNP125R	A
160mm (290kg)	200mm	TE22NNP160H	TE22NNP160HB	TE22NNP160S	TE22NNP160SB	TE22NNP160R	B

Heavy Duty Low Profile 300 - 400kg Capacity

- Double Ball Race Head Set.
- Fully Welded Frame.
- Precision Bearing.
- Nylon Wheel.

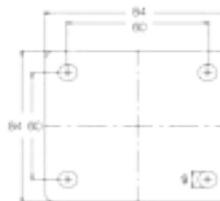

Plate Type A

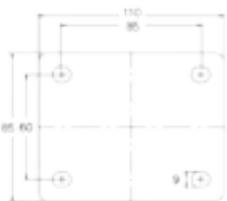

Plate Type B

300 - 400kg CAPACITY		MOUNTING PLATE			
Wheel Diameter	Overall Height	Model	Model	Model	Plate Type
50mm (300kg)	79mm	TE38NZB050S	TE38NZB050SB2	TE38NZB050R	A
75mm (400kg)	105mm	TE37NZB075S		TE37NZB075R	B

Industrial Blue Rubber 130kg - 300kg Capacity



- Double Ball Race Head Set.
- Pressed Metal Frame.
- Zinc Plated Corrosion Resistant Frame.
- Roller Bearing.
- Blue Elastic Rubber.



Bolt Hole Type

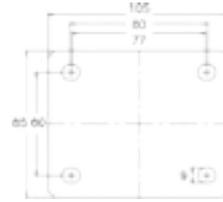

Plate Type A

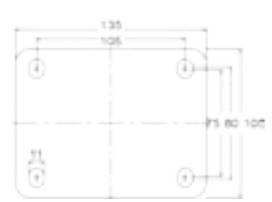

Plate Type B



130kg - 300kg CAPACITY		BOLT HOLE - 12mm			MOUNTING PLATE			
Wheel Diameter	Overall Height	Model	Model	Model	Model	Model	Plate Type	
80mm (130kg)	108mm	TE21ENR080H	TE21ENR080HB	TE21ENR080S	TE21ENR080SB	TE21ENR080R	A	
100mm (140kg)	128mm	TE21ENR100H	TE21ENR100HB	TE21ENR100S	TE21ENR100SB	TE21ENR100R	A	
125mm (180kg)	155mm	TE21ENR125H	TE21ENR125HB	TE21ENR125S	TE21ENR125SB	TE21ENR125R	A	
160mm (300kg)	200mm	TE21ENR160H	TE21ENR160HB	TE21ENR160S	TE21ENR160SB	TE21ENR160R	B	

Industrial Urethane 140kg - 300kg Capacity



- Double Ball Race Head Set.
- Pressed Metal Frame.
- Zinc Plated Corrosion Resistant Frame.
- Roller Bearing.
- Urethane on Nylon.



Bolt Hole Type

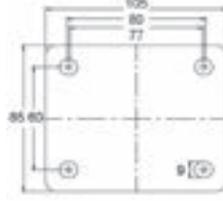

Plate Type A

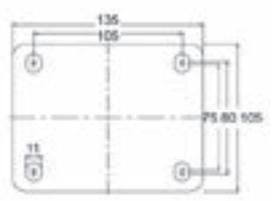

Plate Type B



140kg - 300kg CAPACITY		BOLT HOLE - 12mm			MOUNTING PLATE			
Wheel Diameter	Overall Height	Model	Model	Model	Model	Model	Plate Type	
80mm (140kg)	108mm	TE21UNR080H	TE21UNR080HB	TE21UNR080S	TE21UNR080SB	TE21UNR080R	A	
100mm (150kg)	128mm	TE21UNR100H	TE21UNR100HB	TE21UNR100S	TE21UNR100SB	TE21UNR100R	A	
125mm (190kg)	155mm	TE21UNR125H	TE21UNR125HB	TE21UNR125S	TE21UNR125SB	TE21UNR125R	A	
160mm (300kg)	200mm	TE21UNR160H	TE21UNR160HB	TE21UNR160S	TE21UNR160SB	TE21UNR160R	B	

Industrial White Nylon 180kg - 270kg Capacity



- Double Ball Race Head Set.
- Pressed Metal Frame.
- Zinc Plated Corrosion Resistant Frame.
- Roller Bearing.
- White Nylon.



Bolt Hole Type

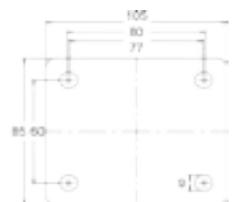

Plate Type



180kg - 270kg CAPACITY		BOLT HOLE - 12mm			MOUNTING PLATE			
Wheel Diameter	Overall Height	Model	Model	Model	Model	Model		
80mm (180kg)	108mm	TE21NNR080H	TE21NNR080HB	TE21NNR080S	TE21NNR080SB	TE21NNR080R		
100mm (190kg)	128mm	TE21NNR100H	TE21NNR100HB	TE21NNR100S	TE21NNR100SB	TE21NNR100R		
125mm (270kg)	155mm	TE21NNR125H	TE21NNR125HB	TE21NNR125S	TE21NNR125SB	TE21NNR125R		

Medium Heavy Duty Rubber 200kg - 400kg Capacity



- Double Ball Race Head Set.
- Pressed Metal Frame - Heavy Duty.
- Zinc Plated Corrosion Resistant Frame.
- Blue Elastic Rubber.
- Precision Bearing.

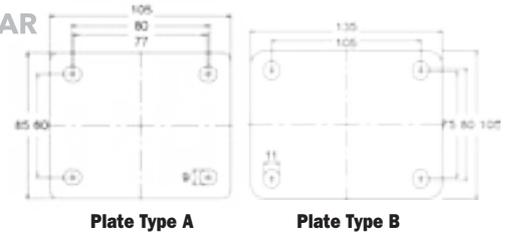

200kg - 400kg CAPACITY		MOUNTING PLATE					
Wheel Diameter	Overall Height			Model	Model	Model	Plate Type
100mm (200kg)	128mm			TE31EZB100S	TE31EZB100SB3	TE31EZB100R	A
125mm (250kg)	155mm			TE31EZB125S	TE31EZB125SB3	TE31EZB125R	A
160mm (300kg)	200mm			TE31EZB160S	TE31EZB160SB3	TE31EZB160R	B
200mm (400kg)	240mm			TE31EZB200S	TE31EZB200SB3	TE31EZB200R	B

Heavy Duty Urethane 250kg - 400kg Capacity



- Double Ball Race Head Set.
- Heavy Duty.
- Welded Metal Frame.
- Urethane on Nylon.
- Precision Bearing.

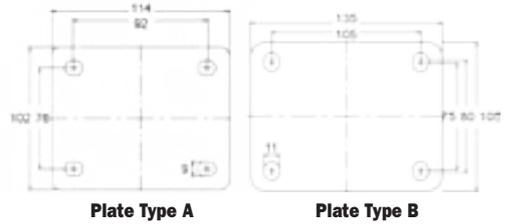

250kg - 400kg CAPACITY		MOUNTING PLATE					
Wheel Diameter	Overall Height			Model	Model	Model	Plate Type
100mm (200kg)	130mm			TE41UPB100S	TE41UPB100SB3	TE41UPB100R	A/B
125mm (250kg)	165mm			TE41UPB125S	TE41UPB125SB3	TE41UPB125R	A/B
150mm (300kg)	195mm			TE41UPB150S	TE41UPB150SB3	TE41UPB150R	A/B

Super Heavy Duty Urethane 300kg - 500kg Capacity



- Precision Bearing Headset.
- Super Heavy Duty.
- Fully Welded Metal Frame.
- Zinc Plated Corrosion Resistant Frame.
- Precision Bearing Wheel.
- Urethane on Nylon.



300kg - 500kg CAPACITY		MOUNTING PLATE		
Wheel Diameter	Overall Height		Model	Model
125mm (300kg)	175mm		TE51UNB125S	TE51UNB125SB
160mm (400kg)	205mm		TE51UNB160S	TE51UNB160SB
200mm (500kg)	250mm		TE51UNB200S	TE51UNB200SB

Super Heavy Duty Urethane 550kg - 800kg Capacity



- Precision Bearing Headset.
- Super Heavy Duty.
- Fully Welded Metal Frame.
- Zinc Plated Corrosion Resistant Frame.
- Precision Bearing Wheel.
- Urethane on Cast Iron.

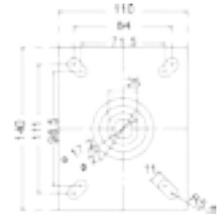

Plate Type



550kg - 800kg CAPACITY		MOUNTING PLATE		
Wheel Diameter	Overall Height	Model	Model	Model
125mm (550kg)	180mm	TE51UIB125S	TE51UIB125SB	TE51UIB125R
160mm (600kg)	210mm	TE51UIB160S	TE51UIB160SB	TE51UIB160R
200mm (800kg)	225mm	TE51UIB200S	TE51UIB200SB	TE51UIB200R

Heavy Duty Urethane 110kg - 400kg Capacity



- Urethane on Cast Iron Wheel.
- Fully Welded Metal Frame.
- Zinc Plated Corrosion Resistant Frame.
- Precision Bearing Wheel.

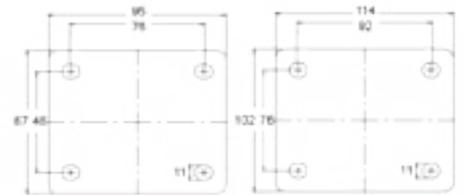

Plate Type A

Plate Type B



110kg - 400kg CAPACITY		MOUNTING PLATE			
Wheel Diameter	Overall Height	Model	Model	Model	Plate Type
75mm (110kg)	106mm	TE60UOC75S	TE60UOC75SB	TE60UOC75R	A
100mm (250kg)	143mm	TE71UOC100S	TE71UOC100SB	TE71UOC100R	B
125mm (300kg)	165mm	TE71UOC125S	TE71UOC125SB	TE71UOC125R	B
150mm (350kg)	191mm	TE71UOC150S	TE71UOC150SB	TE71UOC150R	B
200mm (400kg)	241mm	TE71UOC200S	TE71UOC200SB	TE71UOC200R	B

Kingpinless Extra Heavy Duty 1000kg - 1500kg Capacity



- Kingpinless Head Race.
- Fully Welded Metal Frame.
- Zinc Plated Corrosion Resistant Frame.
- Precision Bearing.
- Urethane on Cast Iron Wheel.

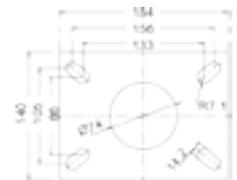

Plate Type



1000kg - 1500kg CAPACITY		MOUNTING PLATE	
Wheel Diameter	Overall Height	Model	Model
200mm (1000kg)	237mm	TE71UXB200S	TE71UXB200R
250mm (1300kg)	292mm	TE71UXB250S	TE71UXB250R
300mm (1500kg)	343mm	TE71UXB300S	TE71UXB300R

Semi Pneumatic - Puncture Proof 100kg Capacity

- Made in Taiwan.
- Puncture Proof Foam Filled Tyres.
- Both 3/4" & 20mm Ball Bearing Sizes Available.



100kg CAPACITY				MOUNTING PLATE	
Wheel Diameter	Overall Height	Tyre Colour	Ball Bearing Size	Model	
265mm (100kg)	265mm	Black	3/4 Inch	PP350 X 4SB34	
265mm (100kg)	265mm	Black	20mm	PP350 x 4SB20	

Y Core Semi Pneumatic - Puncture Proof 50kg - 100kg Capacity

- Made in Australia.
- Heavy Duty Welded Steel Mounting Plate.
- Precision Bearings.
- Sealed Top & Bottom Races to protect Bearings
- Thick 4 & 6 Ply Tyres with tread patterns to suit the wheels most common environments.

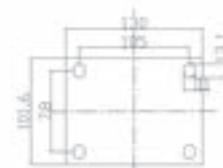

Plate Type



50kg - 100kg CAPACITY				MOUNTING PLATE		
Wheel Diameter	Overall Height	Tyre Colour	Model	Model	Model	
200mm (50kg)	238mm	Grey	YPRIB200	YPRIB200/YZP	YPRIB200/YZF	
250mm (75kg)	288mm	Black	YPLUG250	YPLUG250/YZP	YPLUG250/YZF	
300mm (100kg)	390mm	Black	YPSTR350	YPSTR350/YZP	YPSTR350/YZF	

Y Core Steel Centred - Tube 180kg Capacity

- Made in Australia.
- Heavy Duty Welded Steel Mounting Plate.
- Precision Bearings.
- Sealed Top & Bottom Races to protect Bearings
- Thick 4 & 6 Ply Tyres with tread patterns to suit the wheels most common environments.

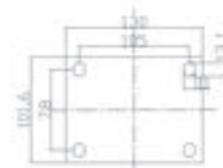

Plate Type



180kg CAPACITY				MOUNTING PLATE		
Wheel Diameter	Overall Height	Model	Model	Model		
250mm (120kg)	288mm	YSLUG250	YSLUG250/YZP	YSLUG250/YZF		
350mm (180kg)	390mm	YSSTR350	YSSTR350/YZP	YSSTR350/YZF		

Semi Pneumatic - Puncture Proof 50kg - 120kg Capacity 



NON-MARKING GREY
Also available in a non-marking Grey tyre - To help protect the finish of sensitive floor areas.

- Polyurethane foam-filled tyres are the premium 'pneumatic' (or semi-pneumatic) wheel option: the wheels are puncture proof and provide the greatest performance and reliability.
- Semi Pneumatics are fitted to Two Piece Wobble-free Steel Centres
- Manufactured from 1.8mm Thick Steel.



		Capacity at speeds					
Wheel Diameter	Wheel Width	8km/hr	15km/hr	Model	Model	Model	Model
200mm (50kg)	50mm	50kg	N/A	P200X50RIB			
220mm (75kg)	54mm	75kg	40kg		P250X4LUG		
265mm (100kg)	70mm	100kg	70kg			P350X4STR	
400mm (120kg)	100mm	120kg	90kg				P400X8KNO

Pneumatic - Steel 120kg - 230kg Capacity 



- Traditional Steel Centre with Inner Tube.
- Welded One Piece Wobble-free Wheels.
- Centres up to and including the 500x6 are manufactured from 1.8mm Steel, and the 650x8 is 2mm Thick Steel.



		Capacity at speeds						
Wheel Diameter	Wheel Width	8km/hr	15km/hr	Model	Model	Model	Model	Model
220mm (120kg)	50mm	120kg	100kg	250X4LUG				
250mm (140kg)	70mm	140kg	110kg		300X4DMD			
320mm (200kg)	80mm	200kg	180kg			350X6KNO		
400mm (220kg)	100mm	220kg	200kg				400X8KNO	
420mm (230kg)	160mm	230kg	200kg					650X8GRA



O Core 300kg - 450kg Capacity



- Made in Australia.
- 5 Year Warranty on Fork.
- 3 Year Warranty on Wheel.
- Excellent Corrosion Resistance.

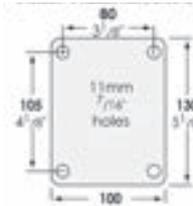

Plate Type A

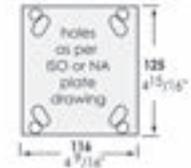

Plate Type B

300kg - 450kg CAPACITY		MOUNTING PLATE					
Wheel Diameter	Overall Height		Model	Model	Plate Type	Model	Plate Type
125mm (300kg)	162mm		HUR125/OZP	HUR125/OZPTB	A	HUR125/OZF	B
150mm (450kg)	189mm		HUR150/OZP	HUR150/OZPTB	A	HUR150/OZF	B
200mm (450kg)	241mm		HUR200/OZP	HUR200/OZPTB	A	HUR200/OZF	B

FALLSHAW CASTORS

O Core 300kg - 400kg Capacity



- Made in Australia.
- 5 Year Warranty on Fork.
- 3 Year Warranty on Wheel.
- Excellent Corrosion Resistance.

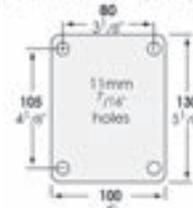

Plate Type A

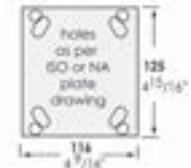

Plate Type B

300kg - 400kg CAPACITY		MOUNTING PLATE					
Wheel Diameter	Overall Height		Model	Model	Plate Type	Model	Plate Type
100mm (300kg)	138mm		OBQ100/OZP	OBQ100/OZPTB	A	OBQ100/OZF	B
125mm (330kg)	162mm		OBQ125/OZP	OBQ125/OZPTB	A	OBQ125/OZF	B
150mm (360kg)	189mm		OBQ150/OZP	OBQ150/OZPTB	A	OBQ150/OZF	B
200mm (400kg)	241mm		OBQ200/OZP	OBQ200/OZPTB	A	OBQ200/OZF	B

Black Rubber Utility Wheel 150kg Capacity



- Puncture Free for Wheelbarrows & Utility Equipment.
- Available with either Double Sealed Precision Ball Bearings for easiest rolling (max speed 10km/hr) or Plain Inserted Bushes for use where wet conditions may be encountered.



150kg CAPACITY			Model - 3/4" Axle	Model - 20mm Axle	
Wheel Diameter	Overall Height				
250mm (150kg)	129mm		R250/50CPRYQ34	R250/50CPRYQ20	

CASTORS & WHEELS

K Series 50kg Capacity 



- Made in Australia.
- 5 Year Warranty on Fork.
- 3 Year Warranty on Wheel.
- Excellent Corrosion Resistance.

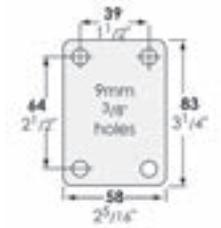

Plate Type



50kg CAPACITY		MOUNTING PLATE		
Wheel Diameter	Overall Height	Model	Model	Model
75mm (50kg)	104mm	KJA75G/KZP	KJA75G/KZPTB	KJA75G/KZF

K Series 65kg Capacity 



- Made in Australia.
- 5 Year Warranty on Fork.
- 3 Year Warranty on Wheel.
- Excellent Corrosion Resistance.

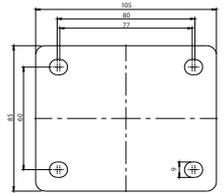

Plate Type



65kg CAPACITY		MOUNTING PLATE		
Wheel Diameter	Overall Height	Model	Model	Model
75mm (65kg)	104mm	KNN75/KZP	KNN75/KZPTB	KNN75/KZF

M Series 100kg Capacity 



- Made in Australia.
- 5 Year Warranty on Fork.
- 3 Year Warranty on Wheel.
- Excellent Corrosion Resistance.



Bolt Hole Type

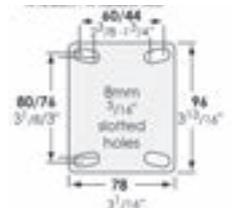

Plate Type



100kg CAPACITY		BOLT HOLE - 12.7mm		MOUNTING PLATE		
Wheel Diameter	Overall Height	Model	Model	Model	Model	Model
75mm (100kg)	106mm			STQ75G/MZP	STQ75G/MZPTB	STQ75G/MZF
100mm (100kg)	135mm	STQ100G/MZH	STQ100G/MZHTB	STQ100G/MZP	STQ100G/MZPTB	STQ100G/MZF

Pneumatic 125 - 135kg Capacity 



- Double Ball Race Head Set.
- Pressed Steel.
- Double Ball Bearing.

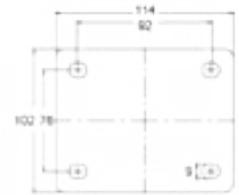

Plate Type B



125kg - 135kg CAPACITY		BOLT HOLE - 12.7mm		MOUNTING PLATE		
Wheel Diameter	Overall Height	Model	Model	Model	Model	Model
200mm (125kg)	250mm			TE43PRB200S		TE43PRB200R
250mm (135kg)	303mm			TE43PRB250S		TE43PRB250R

Scaffold Urethane 800kg Capacity 



- Double Ball Race Head Set.
- Pressed Steel.
- Double Ball Bearing.



800kg CAPACITY		Pintle Size	Model			
Wheel Diameter	Overall Height					
200mm (800kg)	243mm	37.5 x 60mm	TE33UNB200PB			

J Core 150kg - 300kg Capacity 



- Made in Australia.
- 5 Year Warranty on Fork.
- 3 Year Warranty on Wheel.
- Excellent Corrosion Resistance.

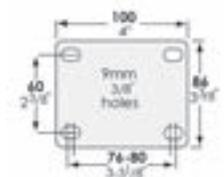

Plate Type



150kg - 300kg CAPACITY		MOUNTING PLATE		
Wheel Diameter	Overall Height	Model	Model	Model
100mm (300kg)	129mm	JUR100JZP	JUR100JZPTB	JUR100JZF

ADJUSTABLE FEET

A multi-adjustable pedestal foot, ideal for industrial, commercial, workshop or food industry applications.

The special insert in the base helps to absorb vibration and means your machinery will stay exactly where you put it.

Model	Spindle Size	Overall Length
AF801650	M16	50mm
AF8016100	M16	100mm
AF8016150	M16	150mm
AF8020100	M20	100mm
AF8020150	M20	150mm
AF8024150	M24	150mm
AF10016100	M16	100mm
AF10016150	M16	150mm
AF10020100	M20	100mm
AF10020150	M20	150mm
AF12520150	M20	150mm
AF12524150	M24	150mm
AFS601250	M12	50mm
AFS6012100	M12	100mm
AFS6012150	M12	150mm

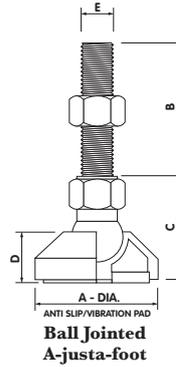

INSERT SIZES

Model	Specifications
S3816	M16 (Square Tube)
S3820	M20 (Square Tube)
S5016	M16 (Square Tube)
S5020	M20 (Square Tube)
S5016	M16 (Round Tube)
S5020	M20 (Round Tube)



EXPANDING SCREW

Model	Dimensions
TER21.5	Ø 19 - 21.5 Round Screw
TER24	Ø 21.5 - 24 Round Screw
TER27	Ø 24 - 27 Round Screw
TER30	Ø 27 - 30 Round Screw
TES21.5	Ø 19 - 21.5 Square Screw
TES24	Ø 21.5 - 24 Square Screw
TES27	Ø 24 - 27 Square Screw
TES30	Ø 27 - 30 Square Screw



TUBES - Butyl Rubber Seamless (Butt-Joined)

Model	Dimensions
SPTUBE250X4	Tube Pneumatic 250X4
SPTUBE300/350X4	Tube Pneumatic 300X4 or 350X4
SPTUBE250X6	Tube Pneumatic 250X6
SPTUBE350X6	Tube Pneumatic 350X6
SPTUBE500X6	Tube Pneumatic 500X6
SPTUBE400X8	Tube Pneumatic 400X8
SPTUBE650X8	Tube Pneumatic 650X8

PFS2.5

Pallet Feet
135 x 135 x 2.5mm.
Top Section
60 x 60mm.



TSWHEELPLATE

130 x 100mm
Mild Steel Raw 5mm Thick.
Hole Centres
80mm x 60mm x 5/16"UNC Holes.
105mm x 80mm x 3/8"UNC Holes.
Pre drilled & threaded holes for easy castor mounting.



LIFTING & HANDLING EQUIPMENT



Pallet Trucks.....	44-45
Scissor Lifts.....	46-49
Lifters, Stackers & Handling.....	50-53
Conveyor Systems.....	54-56
Forklift Attachments.....	57
Crane Accessories.....	58-59
Packaging, Turntables & Ramps.....	60-61
Round & Flat Slings.....	62-65
Chain & Lever Blocks & Hoists.....	66-68
Lifting Chains, Shackles & Eye Bolts.....	69-71
Cargo Handling.....	72-73
Spare Parts.....	74



HYDRAULIC LIFT

**AC25685QL
PALLET TRUCK**

Quick Lift model also available.
Function operates to 250kg.



**AC25
Pallet Truck**

Standard with Urethane Wheels - Nylon Wheels also available
Entry and Exit Roller prevent physical exertion of the operator and protect load roller and pallet.
Totally Sealed Hydraulic Pump with a Slow Lowering Hand Control Valve.
Fully Adjustable Push Rod under forks.
3-Position Control Handle.
Grease Fittings at key points.

Features	Specifications
Capacity	2500kg
Fork Height Range	75 - 185mm
Steering Wheel	200/50mm
Fork Size	160 x 45mm
Fork Overall Width	450/520/685mm
Fork Length	1150mm



HYDRAULIC LIFT

**ACLOW
Low Boy**

Perfect for moving low entry skids with a low height of 51mm.
Not suitable for Chep pallets.



Features	Specifications
Capacity	2000kg
Fork Height Range	51 - 165mm
Steering Wheel	180 x 50mm
Fork Size	160 x 37mm
Fork Overall Width	540mm, 685mm
Fork Length	1150mm



HYDRAULIC LIFT

**ACZ20L
Galvanised Pallet Truck**

Galvanising process gives durable corrosion protection that stands up to the constant abrasion of pallet entry and exit.



Features	Specifications
Capacity	2000kg
Fork Height Range	75 - 190mm
Steering Wheel	180 x 50mm
Fork Size	160 x 50mm
Fork Overall Width	685mm
Fork Length	1150mm



HYDRAULIC LIFT

**ACS20
Stainless Steel Pallet Truck**

All metal parts made completely of Stainless Steel.
Ideal for damp or harsh environments.
Nylon Steering Wheel and Fork Rollers.



Features	Specifications
Capacity	2000kg
Fork Height Range	75 - 190mm
Steering Wheel	180 x 50mm
Fork Size	160 x 50mm
Fork Overall Width	685mm
Fork Length	1150mm

All Measurements are Length x Width x Height

www.teamsystems.net.au



**ACL20
Super Long Pallet Truck**

Designed to carry goods with big volume.

Features	Specifications
Capacity	2000kg
Fork Height Range	75 - 190mm
Steering Wheel	200 x 50mm
Fork Size	160 x 60mm
Fork Overall Width	685mm
Fork Length	1800mm



**AC25/800
Stubbie Pallet Trucks**

Designed to carry goods with big volume.

Features	Specifications
Capacity	2500kg
Fork Height Range	75 - 190mm
Steering Wheel	200 x 50mm
Fork Size	160 x 60mm
Fork Overall Width	450/520mm
Fork Length	800mm



**WAQ25E540/WAQ25E685
Pallet Truck with Scales**

Great alternative for users who need pallet weights for transportation.

Features	Specifications
Capacity	2000kg
Fork Height Range	88 - 200mm
Steering Wheel	180 x 50mm
Fork Size	178 x 60mm
Fork Overall Width	540/685mm
Fork Length	1150mm



**AC20HO
Hand Braked Equipped Pallet Truck**

Brake complies to OHS recommendation.

Huge 2000kg Capacity.

Features	Specifications
Capacity	2000kg
Fork Height Range	85 - 200mm
Fork Size	160 x 50mm
Fork Overall Width	685mm
Fork Length	1150mm
Steering Wheel	Rubber on Cast
Load Roller	Single/Tandem Nylon Polyurethane
Weight	82kg

All Measurements are Length x Width x Height

ELECTRIC LIFT



EX Electric Scissor Lift Pallet Truck

Quick Lift Function doubles lift speed for loads weighing 250kg or less. Skid Lifter suitable as a lift table or work bench. One Cylinder System guarantees no risk of dropping to the second piston suddenly.

NOTE: Not suitable for CHEP style Pallets.

Features	Specifications
Capacity	1000kg
Fork Height Range	85 - 800mm
Fork Size	160 x 50mm
Fork Overall Width	540/680mm
Fork Length	1170mm
Battery	12V/60Ah
Motor	0.8Kw
Weight	169kg

HYDRAULIC LIFT



HLTN10 High Lift Pallet Truck

Skid Lifter suitable as a lift table or work bench. Stabilisers ensure maximum stability.

NOTE: Not suitable for CHEP style Pallets.

Features	Specifications
Capacity	1000kg
Fork Height Range	85 - 800mm
Fork Size	160 x 50mm
Fork Overall Width	540/680mm
Fork Length	1150mm
Fork Rollers	75 x 50mm
Big Wheel	180 x 50mm
Weight	128/133kg



ELECTRIC LIFT & DRIVE



LPT15 - Power Pallet Truck

German Drive. European Hydraulic Motor.

Features	Specifications
Capacity	1500kg
Lifting Height	120mm
Minimum Height	85mm
Fork Overall Width	700mm
Fork Length	1150mm
Battery	24V
Motor	700W
Weight	286kg



ELECTRIC LIFT & DRIVE



ECL1029M Wide Leg Electric Platform Stacker

Built-in Charger. 4-Wheel Design with sideways tiller for high stability and perfect view.

Features	Specifications
Capacity	1000kg
Fork Height Range	2840mm
Fork Width	1400mm
Fork Length	1150mm
Mast Height Minimum	1950mm
Weight	530kg

All Measurements are Length x Width x Height

www.teamsystems.net.au

Eliminate back injuries using our hydraulic scissor lift tables. Versatile and safe way of transporting and handling of goods in offices, warehouses, workshops, Industry bays, hospitals and retail.



HYDRAULIC LIFT



TF15

Positive braking system on rear wheels for safety.
Handle folds flat for easy storage.

Features	Specifications
Capacity	150kg
Table Height Range	220 - 750mm
Table Dimensions	700 x 450 x 36mm
Wheel Diameter	100 x 25mm
Handle Height from ground	950mm
Weight	49kg



HYDRAULIC LIFT



TF30 & TF50

Overload valve ensures load limit is not exceeded.

Features	TF30	TF50
Capacity	300kg	500kg
Table Height Range	285 - 880mm	285 - 880mm
Table Dimensions	850 x 500 x 50mm	815 x 500 x 50mm
Wheel Diameter	125 x 40mm	125 x 40mm
Handle Height from ground	990mm	990mm
Weight	77kg	81kg

SCISSOR LIFTS



HYDRAULIC LIFT



TFD35

High Lift 1300mm.
Double Lift.

Features	Specifications
Capacity	350kg
Table Height Range	355 - 1300mm
Table Dimensions	910 x 500 x 53mm
Wheel Diameter	125 x 40mm
Handle Height from ground	975mm
Weight	136kg



HYDRAULIC LIFT



TF75

1000 x 510mm Deck.
750kg Capacity.

Features	Specifications
Capacity	750kg
Table Height Range	420 - 900mm
Table Dimensions	1000 x 510 x 55mm
Wheel Diameter	147 x 50mm
Handle Height from ground	1000mm
Weight	120kg

All Measurements are Length x Width x Height



LIFTING & HANDLING EQUIPMENT



HYDRAULIC LIFT

TFD70

Large Deck Size.
700kg Capacity.

Features	Specifications
Capacity	700kg
Table Height Range	450 - 1500mm
Table Dimensions	1220 x 610 x 53mm
Wheel Diameter	125 x 40mm
Handle Height from ground	1015mm
Weight	170kg



TG100

HYDRAULIC LIFT



TG50

TG50 & TG100

Huge Deck Size.

Features	TG50	TG100
Capacity	500kg	1000kg
Table Height Range	286 - 915mm	360 - 1400mm
Table Dimensions	1600 x 810 x 55mm	2050 x 750 x 55mm
Wheel Diameter	127mm	80mm rear/180mm front
Handle Height from ground	990mm	990mm
Weight	154kg	198kg



ELECTRIC LIFT

ETF50

Electric Lifting.
Great for loads up to 500kg.

Features	Specifications
Capacity	500kg
Table Height Range	440 - 1025mm
Table Dimensions	1010 x 520 x 50mm
Wheel Diameter	150 x 48mm
Handle Height from ground	970mm
Weight	157kg



ELECTRIC LIFT

ETFD35

Double Electric Lift.
Lifts to 1300mm.

Features	Specifications
Capacity	350kg
Table Height Range	370 - 1300mm
Table Dimensions	910 x 500 x 53mm
Wheel Diameter	125 x 40mm
Handle Height from ground	920mm
Weight	142kg

All Measurements are Length x Width x Height

www.teamsystems.net.au

SCISSOR LIFT



TF50S
Scissor Lift Table

Stainless Steel Construction.
Galvanised Scissors & Pump.

Features	Specifications
Capacity	450kg
Minimum Height	290mm
Maximum Height	890mm
Platform Size (Length x Width)	815 x 500mm

SCISSOR LIFT



TFD15S



TFD15S/TFD35S
Scissor Lift Table

Stainless Steel Construction.
Galvanised Scissors & Pump.

Features	TFD15S	TFD35S
Capacity	100kg	350kg
Minimum Height	250mm	355mm
Maximum Height	1220mm	1295mm
Platform Size (Length x Width)	700 x 445mm	910 x 500mm

ELECTRIC LIFT



HTFG

Remote Power System, easy for controlling, convenient for maintenance.
Electronic Controlling Box with UP, DOWN & Emergency Buttons.
Electric Controlling System is imported from Europe.
Includes Ramp - Size: 1450mm wide x 1140mm long.

Features	Specifications
Capacity	1000kg
Lowered Height	82mm
Raised Height	760mm
Platform Size	1450 x 1140mm
Lift Speed	8 Seconds
Motor	0.75Kw - 3 Phase
Power Supply	3 Phase
Weight	250kg

ELECTRIC LIFT



HIW4

Made of High Quality Steel and is designed to be durable, reliable and easy to use.
Electric Controlling System is imported from Europe.
Compact Structure gives balanced lifting and lowering.
Large Capacity.

Features	Specifications
Capacity	2000kg
Lowered Height	190mm
Raised Height	1010mm
Platform Size	1300 x 800mm
Lift Speed	40 Seconds
Motor	0.75Kw - 3 Phase
Power Supply	3 Phase
Weight	280kg

All Measurements are Length x Width x Height



HYDRAULIC LIFT



**NFM60 & NFM180
Hydraulic Furniture Movers**

For professional transport of heavy items.

Features	NFM60	NFM180
Capacity	600kg	1800kg
Lift Height	300mm	250mm
Wheels	145mm	145mm



ELECTRIC LIFT



HTFU

Remote Power System, easy for controlling, convenient for maintenance. Electronic Controlling Box with UP, DOWN & Emergency Buttons. Specially designed in "U" shape for handling pallets and boxes. Electric Controlling System is imported from Italy.

Features	Specifications
Capacity	1000kg
Lowered Height	80mm
Raised Height	780mm
Platform Size	1420 x 1140mm
Lift Speed	18 Seconds
Motor	0.75Kw - 3 Phase
Power Supply	3 Phase
Weight	235kg



ELECTRIC LIFT



**MES150
Lifter Transporter**

Ideal for Laboratory, Office & Light Industrial. Rechargeable Battery.

Features	Specifications
Capacity	150kg
Lifting Height	1535mm
Fork Overall Width	520mm
Fork Length	460mm
Battery	12V/ 7Ah
Motor	12V
Weight	58kg



WINCH LIFT



**WFH181
Hand Stacker**

Lightweight Stacker - Great for Tradespeople!
Folds and loads easily into a ute or station wagon. Compact design allows you to lift and manoeuvre in tight work areas/spaces.

Features	Specifications
Capacity	181kg
Fork Height Range	90 - 2400mm
Fork Overall Width	630mm
Fork Length	570mm
Dimensions	850 x 650 x 2500mm
Weight	60kg

All Measurements are Length x Width x Height

www.teamsystems.net.au



HYDRAULIC LIFT



FP0415 Platform Stacker

Foot Pedal Operation.
 Overload Protection Valve Equipped.
 Hard Chrome-plated Frame.
 Two Frame Rollers and two Steering Rollers ensures a stable and safe operation.

Features	Specifications
Capacity	400kg
Lift Range	200 - 1500mm
Platform Size	590 x 650mm
Wheels	4
Overall Height	1630mm
L x W x H	1015 x 590 x 1630mm
Weight	91kg



HYDRAULIC LIFT



3W219 Standard Steel Lifter

Features	Specifications
Capacity	340kg
Lift Range	10 - 1350mm
Platform Size	560 x 560mm
Wheels	2
Overall Height	1545mm
L x W x H	880 x 570 x 1545mm
Weight	80kg



ELECTRIC LIFT



EPS0415 Electric Platform Stacker

Electric Lift - Manual Push.
 Special design combines lifting, transporting and stacking function together.

Features	Specifications
Capacity	400kg
Fork Height Range	85 - 1500mm
Platform Size (Length x Width)	650 x 576mm
Battery	DC12V 60AH
Motor	DC12V 700W

All Measurements are Length x Width x Height



HYDRAULIC LIFT



SFH & SFH10W Hand Stackers

SFH10W Model can straddle the Pallet.

Features	SFH15	SFHD10	SFHD10W
Capacity	1500kg	1000kg	1000kg
Fork Height Range	85 - 1600mm	85 - 2500mm	85 - 1600mm
Fork Size	150/160 x 60mm	150/160 x 60mm	150/160 x 60mm
Fork Overall Width	300 - 740mm	300 - 740mm	300 - 1360mm
Fork Length	1200mm	1200mm	900mm
Mast Height Min.	1980mm	1830mm	1980mm
Weight	260kg	300kg	262kg



WINCH LIFT



MER 35 Aluminium Stacker

Rolls easily through single door in upright position.
No Tool - Quick Set-up.
Compact Design, legs fold up for easy storage.

Features	Specifications
Capacity	350kg
Max. Working Height	3500mm
Overall Length	1500mm
Weight	120kg



HYDRAULIC LIFT



MER 50 Aluminium Stacker

Fits through a standard door.
Folding Stabilisers for compact storage.
Aluminium Telescopic Mast System.

Features	Specifications
Capacity	300kg
Max. Working Height	5000mm
Overall Length	1880mm
Weight	145kg



RAMP OPTION FITTED

WBA100 & WBA200 Low Profile Floor Scales

Rugged Steel Diamond Plate Surface with Heavy Duty Welded Support Channel.
6 Digit, 7 Segment Display.

Available Options

Ramps WBB36 to suit WBA100.
Ramps WBB48 to suit WBA200.

Features	WBA100	WBA200
Measuring Range	1000kg	2000kg
Indexing Accuracy	0.2kg	0.25kg
Platform Size	915 x 915mm	1220 x 1220mm
Height	70mm	70mm
Weight	75kg	145kg

All Measurements are Length x Width x Height

www.teamsystems.net.au



ELECTRIC DRIVE



TE10 Electric Tow Tractor

Allows easy pulling operations in low duty applications on short distances.
Ideal for pulling supermarket trolleys, baggage carts or trailers.
Compact Design with a robust Drive Axle.

Features	Specifications
Capacity	1000kg
Tiller Heights (Min/Max)	750mm/1258mm
Overall Dimensions (Length/Width)	810mm/490mm
Travel Speed	4.2km/h
Weight	62kg



 **Electrodrive**



TUG COMPACT
500kg Electric Powered Tug

500kg Capacity.
Safely move trolleys or wheeled objects and equipment.
Simple to use, no driver's licence required.
Low Maintenance.

 **Electrodrive**



TUG EVO
1000kg & 2000kg Electric Powered Tug

1000kg or 2000kg Capacity.
Safely move trolleys or wheeled objects and equipment.
Simple to use, no driver's licence required.
Low Maintenance.

LIFT MASTER



NIFTY LIFT 30
30kg Manual Bin Lifter

30kg Capacity.
Aids in the lifting and emptying of Wheelie Bins.
Lifts 120L & 240L Bins.
'Full Swing' Lift Action.
Suitable for small offices, retail outlets and factories that dispose of paper and general waste once or twice a day.

LIFT MASTER



BLHP 1500
RUGGED MANUAL
100kg Manual Bin Lifter

100kg Capacity.
Aids in the lifting and emptying of Wheelie Bins.
Lifts 80L, 120L, 140L & 240L Bins.
'Full Swing' Lift Action.
Hydraulic Hand Pump Operation.
Small foot print fits through internal doorways.
Perfect for Building Sites or where manouverability of Bin is required.

LIFT MASTER



BLEH 1500
RUGGED POWERED
150kg Powered Bin Lifter

150kg Capacity.
Aids in the lifting and emptying of Wheelie Bins.
Lifts 80L, 120L, 140L & 240L Bins.
'Full Swing' Lift Action.
Hydraulic Hand Pump Operation.
Includes 12V Battery and Smart Charger.
Small foot print fits through internal doorways.
Perfect for Building Sites or where manouverability of Bin is required.

THE TEAM SYSTEMS 'DIY CONVEYOR SYSTEM'

Team Systems full range of Imported Gravity Conveyors provides the simple solution for moving all types of products in industries such as transport, distribution centres, container unloading & similar.

Roller Conveyor are one of the most common types of conveyors applied in conveying flat bottom type products such as cases, boxes, pallets & trays. These kind of conveyors improve efficiency distribution & line links between different stages of production of your product.

STEP 1



STEP 1.

- Choose type of Roller
- Choose length of Roller.
- Choose number of Rollers.

STEP 2



STEP 2.

- Choose matching Frame width.
- Choose length of Frame.

STEP 3



STEP 3.

- Choose matching Stands to suit Conveyor Frame.

ASSEMBLED CONVEYOR



PVC ROLLERS



STEEL ROLLERS

Team Systems Gravity Conveyor is ideally suited to handling operations which cannot justify the expense of powered equipment. They provide efficient handling at negligible running costs.

Gravity Conveyors are very easy to set up, dismantle or re-locate.

Available with either PVC or zinc plated rollers and three standard widths.

Rollers have spring loaded shafts for easy installation and hassle free maintenance.

It is recommended that there be a minimum of three rollers under the goods to be transported at any time.

Roller Pitch is determined by the size of goods to be transported, in the instances of various sizes, roller pitch is determined by the size of the smallest goods to be transported.

CONVEYOR ROLLERS - PVC & STEEL - Q Shaft 10 x 8

Model	Roller Width - A	Roller Diameter - B	Capacity
TSPROLL300 PVC	230mm	50mm	40kg/ea
TSPROLL450 PVC	380mm	50mm	30kg/ea
TSPROLL600 PVC	530mm	50mm	20kg/ea
TSSROLL300 STEEL	230mm	50mm	120kg/ea
TSSROLL450 STEEL	380mm	50mm	120kg/ea
TSSROLL600 STEEL	530mm	50mm	120kg/ea

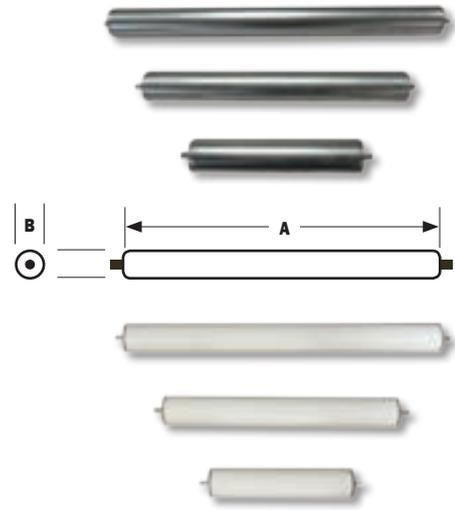

PART 1 - ROLLERS - PVC & STEEL

CONVEYOR SYSTEMS

The frames are made from strong mild steel and powder coated finish in royal blue. Interlocking sections make for greater flexibility for additions and subtractions of further lengths.

Team Systems Adjustable Conveyor Stands provide a rigid footing for Gravity Conveyors.

Adjustable height provides flexibility in application.

It is recommended that Conveyor Stands be securely fixed into position.

CONVEYOR FRAME - Mild Steel/Blue

Model	Dimensions	Pitch
TSFRAME300 - 1.5	300mm wide x 1500mm length	75mm (min)
TSFRAME300	300mm wide x 3000mm length	75mm (min)
TSFRAME450 - 1.5	450mm wide x 1500mm length	75mm (min)
TSFRAME450	450mm wide x 3000mm length	75mm (min)
TSFRAME600 - 1.5	600mm wide x 1500mm length	75mm (min)
TSFRAME600	600mm wide x 3000mm length	75mm (min)



ADJUSTABLE STANDS - Mild Steel/Blue

Model	Width	Minimum Height	Maximum Height
TSFTC300	300mm	720mm	1100mm
TSFTC450	450mm	720mm	1100mm
TSFTC600	600mm	720mm	1100mm

PART 2 - FRAME WORK

CONVEYOR SYSTEM COMPLETED

Team Systems Gravity Conveyors give you the flexibility to DIY for your own particular handling requirement.

We can offer pre-packed ready to assemble options to manage freight availability or fully assembled to your requirement to reduce downtime in assembling.

Additional parts like castors for mobility, hook bars for connectivity & many other accessories to efficiently convey products through the lines of your production or despatch areas.



PART 3 - ASSEMBLY

LIFTING & HANDLING EQUIPMENT



EXPANDABLE CONVEYOR - SKATE & ROLLER MODEL

A unique flexible conveyor that expands, contracts, twist and turns. Quick set-up and adjustable height legs on lockable castors. Skate wheels or rollers designed to ensure self-tracking.

Expandable gravity roller and skate-wheel conveyors provide an economical solution in material handling.

These conveyors are ideally suited for packaging, transporting and manufacturing lines.

A proven performer loading and unloading.

C18HS - Heavy Duty Skate Wheel

Features	EC450S	EC600S
Length - Extended	3900mm	3900mm
Length - Retracted	1000mm	1000mm
Width	450mm	600mm
Load Capacity	100kg/per metre	100kg/per metre
Castors	125mm	125mm
Height Range	690-1000mm	690-1000mm

C18HR - Heavy Duty Steel Roller

Features	EC450R	EC600R
Length - Extended	3900mm	3900mm
Length - Retracted	1450mm	1450mm
Width	450mm	600mm
Load Capacity	130kg/per metre	130kg/per metre
Castors	125mm	125mm
Height Range	690-1000mm	690-1000mm

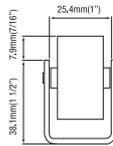

Carton Flow Rail

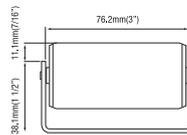

Roller Rail

Carton Flow Rail - CFRA3337

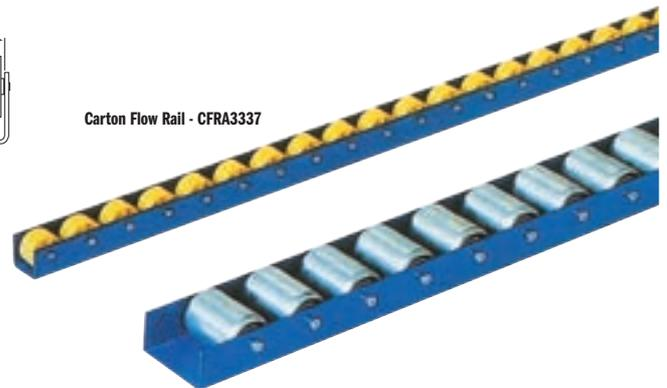

Roller Rail - RR3000

CARTON/PALLET LIVE STORAGE

Team Systems offers a variety of Flow systems for every size warehouse and every price range.

All systems are gravity-driven and perfect for applications when numerous size cartons require picking.

Stock presents on a First-In/First-Out basis, which ensures inventory rotation. Separating the loading aisle from the retrieval aisle allows pickers to operate more efficiently.

Carton Flow can be integrated with conveyors and other storage solutions to create functional pick modules and warehouse product picking efficiency.

Features	CFRA3337	RR3000
Load Capacity	70kg/per metre	120kg/per metre
Length	3m	3m



NK25 - Fork Hook

Features	Specifications
Capacity	2500kg
Maximum Fork Section	160 x 160mm
Weight	25kg

ARE30 Telescopic Fork Mounted Jib

Slip-On Mounted Installation Method.
Weighs 230kg.

LIFTING CAPACITY CHART

Inner Position	Length	Capacity
A	740mm	3000kg
B	969mm	2291kg
C	1198mm	1853kg
D	1427mm	1556kg
E	1656mm	1341kg
F	1885mm	1178kg
G	2114mm	1050kg
H	2352mm	944kg
I	2581mm	860kg
J	2810mm	790kg
K	3039mm	730kg
L	3268mm	679kg
M	3497mm	635kg
N	3726mm	596kg

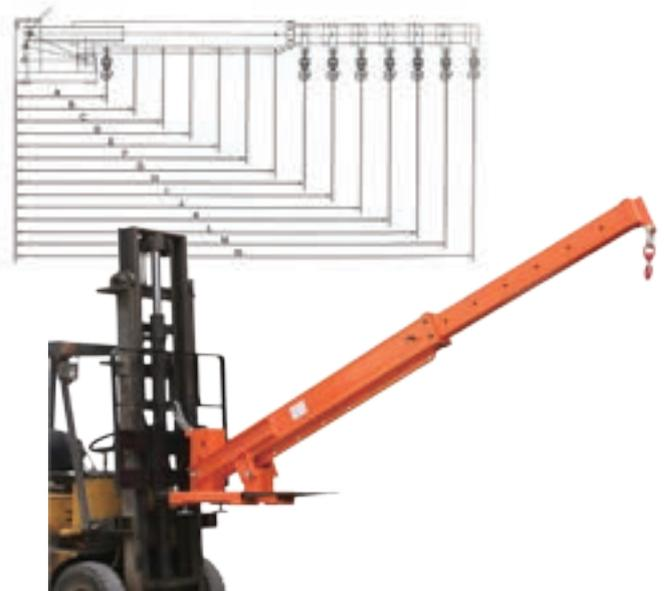

NLB6430 Telescopic Fork Mounted Jib

Converts a forklift truck into a mobile crane.
Slip-On Mounted Installation Method.
Weighs 190kg.

LIFTING CAPACITY CHART

Inner Position	Length	Capacity
A	756mm	3000kg
B	986mm	2300kg
C	1216mm	1865kg
D	1446mm	1568kg
E	1676mm	1353kg
F	1906mm	1190kg
G	2138mm	1061kg
H	2367mm	958kg
I	2596mm	874kg
J	2825mm	803kg
K	3054mm	743kg
L	3283mm	691kg
M	3512mm	648kg
N	3741mm	606kg

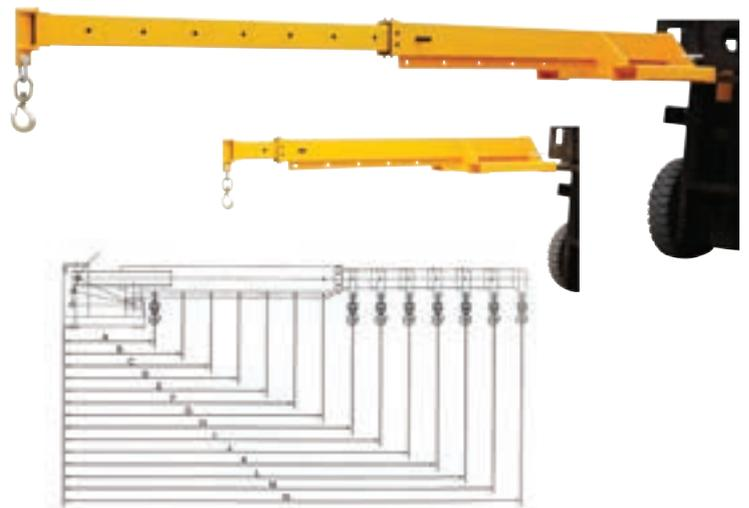

CRANE
LIFT WITH CONFIDENCE



B10 Gantry Crane

Solid Steel Construction.
Quick Setup Design.
Greater flexibility than permanently fixed cranes.
Large Castors with Roller Bearings facilitate mobility from one area to another.

Features	Specifications
Capacity	1000kg
Span	3.0m
Height	3.0m - 4.0m Adjustable

CRANE
LIFT WITH CONFIDENCE



TFC254540F Folding Arm Freestanding Jib Crane

Supports Tool Balancers, Air Balancers, Vacuum Lifters & Hoists.
Safety Yellow Finish.
Designed for machine & maintenance Industries for the safe loading & unloading of heavy awkward loads.
Can be fixed to level surface either indoor or outdoor.
Various sizes available.

Features	Specifications
Capacity	250kg
Height	4.5m
Turning Radius	4.0m
Rotating Angle	360°

CRANE
LIFT WITH CONFIDENCE



TFC254540 Straight Arm Freestanding Jib Crane

Supports Tool Balancers, Air Balancers, Vacuum Lifters & Hoists.
Safety Yellow Finish.
Designed for machine & maintenance Industries for the safe loading & unloading of heavy awkward loads.
Can be fixed to level surface either indoor or outdoor.

Features	Specifications
Capacity	250kg
Height	4.5m
Turning Radius	4.0m
Rotating Angle	360°

CRANE
LIFT WITH CONFIDENCE



ASA10 & ASA20 Double & Single Scissor Action Pallet Pullers

Used to pull pallets and slide heavy crates to edge of dock or truck.
Variable Jaw Width grabs pallet securely and automatically releases.
Self Cleaning Heads.
Single Scissor Action allows for a wider jaw opening.

Model	Scissor Action	Suits Stringers	Load Capacity
ASA10	762mm	Up to 76mm	2273kg
ASA20	495mm	Up to 140mm	2273kg



Girder Trolley

Powdercoat Finish.
Fully Certified AS1418.2.
Anti Drop Plates.
Smooth, Heavy Duty Bearings.

Model	Capacity	i-Beam Width Range	Weight
CT01	1000kg	64 - 203mm	9.5kg
CT02	2000kg	88 - 203mm	14.5kg
CT03	3000kg	100 - 203mm	24.5kg
CT04	5000kg	114 - 203mm	37.8kg



Beam Clamp

Powdercoat Finish.
Fully Certified AS4991 2004.

Model	Capacity	i-Beam Width Range	Weight
CB01	1000kg	75 - 220mm	4.5kg
CB02	2000kg	75 - 220mm	5kg
CB03	3000kg	80 - 320mm	9.5kg
CB04	5000kg	80 - 320mm	11kg



WCB05

WCB10

WCB05/WCB10
500 - 1000kg Crane Scales

Model	Measuring Range	Accuracy	Weight
WCB05	500kg	0.2kg	5kg
WCB10	1000kg	0.5kg	11kg



WCB20

WCB30

WCB20/WCB30
2000 - 3000kg Crane Scales

Model	Measuring Range	Accuracy	Weight
WCB20	2000kg	1kg	11kg
WCB30	3000kg	1kg	15kg



**PLG1
TeamStar Pallet Leveller**

Keeps the active layer of the load at or above waist height, eliminating bending and lifting, helping to reduce LTI cause by strains and repetitive movement. The leveller utilises a scissor type action with varying springing combinations that can be adjusted to provide load capacities up to 2000kg. A Low Friction Bearing supported turntable assists in load rotation. No ground fixing required.

Features	Specifications
Capacity	200 - 2000kg
Rotating Platform Diameters	1110mm
Compressed Height	270mm
Extended Height	710mm
Base Size	1150 x 934mm
Pocket Size	170 x 50mm
Weight	168kg



PLT1 & PLT2.5 - TeamStar Lift Pallet Levelling Table

Team Lift is a load elevating and lowering device manufactured to reduce bending when unloading & loading goods from a pallet. Team Lift's simple, safe, robust design saves time, money and reduces injuries. Eliminates backstrain and reduces the risk of staff injuries. Keeps pallets at a constant waist height. Simple 5 minute job to change springs. Pallet Truck & Fork Lift Entry. Galvanised or Stainless Steel Optional. PLT1 1000kg Model PLT2.5 2500kg Model

Features	Specifications
Min. Height	380
Max. Height	880
Base Size	1150 x 880mm
Turntable Size	1220 x 1120mm
Weight	175kg



ORBIT1000 - Orbitwrap Stretch Wrap Machine

Electronic Screen with Soft Touch Control. Front Fork Relocation Slots. Automatic or Manual Programs. Automatic Photocell Load Height Detection. Pause Function. Top and Bottom Wrap Number Programs. Adjustable Film Carriage Speeds. Adjustable Turntable Speeds. Adjustable Spring Brake Tension System. Ramp for Pallet Truck Access. Excellent Value for Small to Medium Sized Operations.

Features	Specifications
Capacity	1500kg
Speed	10RPM
Power Voltage	240V Single Phase
Wrap Height	2.2m
Turntable	Ø1520 - 80mm Low Profile



Available Options:
Wrap Height: 2.7m.
Turntable Diameter: 1800mm & 2200mm.



**CR7E
Floor Container Ramp**

Fixed Height Lip 1600mm.
The CR Series is designed primarily for bridging into a standard container from ground level.

Model	Size	Width	Load Capacity	Weight
CR7E	1260mm	2200mm	7000kg	330kg

PALRING - Turntable

Palring is a tough, galvanised turntable with 2 tonne capacity that won't bind or tighten under load. Available in 900mm or 1100mm diameters. Suitable applications include manual palletising or depalletising, loading or unloading stillages, containers, bins, bags, bricks, tiles. Commonly used alongside conveyors, feeding hoppers, extruders, process and production equipment.



Features	Specifications
Capacity	2000kg
Height	60mm
Turntable Diameter	1100 or 900mm
Overall Diameter	1100 or 900mm
Weight	26kg

from this...



to this.



**EP1 1000kg
OH&S EASI PICKER**

Ideal to pick or retrieve goods at lower levels, in awkward or hard to get at places. Ideal for use in retail stores, warehouses, document storage facilities.

Features	Specifications
Dimensions	Standard - 1180 x 1180 x 1180 x 120mm Extended - 1180 x 2300 x 2300 x 120mm
Features	Powder Coated Yellow & Black, Galvanised, Zinc Plated or S/Steel
Sizes	Special Sizes from 1800mm to 3000 x 120mm on request
Weight	50kg

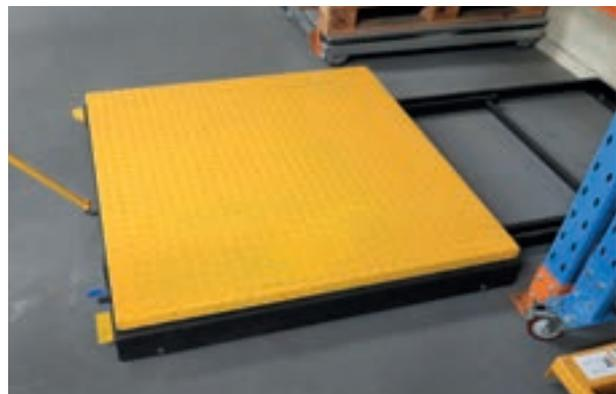

**NEW
LOCKING
SYSTEM**

**OPTIONAL SELF
LOCKING SYSTEM
Now available on our
Range of Easi Pickers**

CRANE

LIFT WITH CONFIDENCE

Robust and made at the highest quality.
Ideal for heavy lifting.

- Safety Factor = 8 to 1
- AS1353 - 1997 Compliant
- Custom Flat Slings made to order*
*subject to lead times



FULLY CERTIFIED



ROBUST TAGS



SUPER BRIGHT DENSE FABRIC



REINFORCED EYES



Flat Sling WLL 3000kg - Yellow

Code	Length
FS31	1m
FS31.5	1.5m
FS32	2m
FS32.5	2.5m
FS33	3m
FS33.5	3.5m
FS34	4m
FS35	5m
FS36	6m
FS37	7m
FS38	8m
FS39	9m
FS310	10m

Flat Sling WLL 1000kg - Violet

Code	Length
FS1.5	0.5m
FS11	1m
FS11.5	1.5m
FS12	2m
FS12.5	2.5m
FS13	3m
FS13.5	3.5m
FS14	4m
FS15	5m
FS16	6m
FS17	7m
FS18	8m
FS19	9m
FS110	10m



Flat Sling WLL 4000kg - Grey

Code	Length
FS42	2m
FS43	3m
FS44	4m
FS45	5m
FS46	6m
FS47	7m
FS48	8m
FS49	9m
FS410	10m

Flat Sling WLL 2000kg - Green

Code	Length
FS2.5	0.5m
FS21	1m
FS21.5	1.5m
FS22	2m
FS22.5	2.5m
FS23	3m
FS23.5	3.5m
FS24	4m
FS25	5m
FS26	6m
FS27	7m
FS28	8m
FS29	9m
FS210	10m



Flat Sling WLL 5000kg - Red

Code	Length
FS53	3m
FS54	4m
FS55	5m
FS56	6m
FS57	7m
FS58	8m
FS59	9m
FS510	10m



Flat Sling WLL 6000kg - Brown

Code	Length
FS63	3m
FS64	4m
FS65	5m
FS66	6m
FS67	7m
FS68	8m
FS69	9m
FS610	10m



Flat Sling WLL 8000kg - Blue

Code	Length
FS83	3m
FS84	4m
FS85	5m
FS86	6m
FS87	7m
FS88	8m
FS89	9m
FS810	10m



Flat Sling WLL 10000kg - Orange

Code	Length
FS103	3m
FS104	4m
FS105	5m
FS106	6m
FS107	7m
FS108	8m
FS109	9m
FS1010	10m



CRANE

LIFT WITH CONFIDENCE

High Quality, dense fabric, protects the internal fibres which promotes a longer operational life.

- Safety Factor = 7 to 1
- AS4497 - 1997 Compliant
- Custom Round Slings made to order*
*subject to lead times

 FULLY CERTIFIED

 ROBUST TAGS

 HIGHEST QUALITY

 TAG PROTECTION

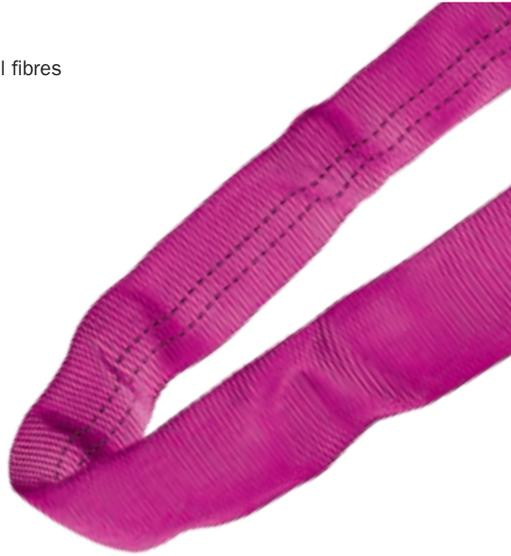

Round Sling WLL 3000kg - Yellow

Code	Length
RS31	1m
RS31.5	1.5m
RS32	2m
RS32.5	2.5m
RS33	3m
RS33.5	3.5m
RS34	4m
RS35	5m
RS36	6m
RS37	7m
RS38	8m
RS39	9m
RS310	10m

ROUND SLINGS

Round Sling WLL 1000kg - Violet

Code	Length
RS1.5	0.5m
RS11	1m
RS11.5	1.5m
RS12	2m
RS12.5	2.5m
RS13	3m
RS13.5	3.5m
RS14	4m
RS15	5m
RS16	6m
RS17	7m
RS18	8m
RS19	9m
RS110	10m



Round Sling WLL 4000kg - Grey

Code	Length
RS41	1m
RS42	2m
RS43	3m
RS44	4m
RS45	5m
RS46	6m
RS47	7m
RS48	8m
RS49	9m
RS410	10m

Round Sling WLL 2000kg - Green

Code	Length
RS2.5	0.5m
RS21	1m
RS21.5	1.5m
RS22	2m
RS22.5	2.5m
RS23	3m
RS23.5	3.5m
RS24	4m
RS25	5m
RS26	6m
RS27	7m
RS28	8m
RS29	9m
RS210	10m



Round Sling WLL 5000kg - Red

Code	Length
RS51	1m
RS52	2m
RS53	3m
RS54	4m
RS55	5m
RS56	6m
RS57	7m
RS58	8m
RS59	9m
RS510	10m

LIFTING & HANDLING EQUIPMENT



Round Sling WLL 6000kg - Brown

Code	Length
RS62	2m
RS63	3m
RS64	4m
RS65	5m
RS66	6m
RS67	7m
RS68	8m
RS69	9m
RS610	10m



Round Sling WLL 8000kg - Blue

Code	Length
RS82	2m
RS83	3m
RS84	4m
RS85	5m
RS86	6m
RS87	7m
RS88	8m
RS89	9m
RS810	10m



Round Sling WLL 10000kg - Orange

Code	Length
RS102	2m
RS103	3m
RS104	4m
RS105	5m
RS106	6m
RS107	7m
RS108	8m
RS109	9m
RS1010	10m





E-SERIES Chain Blocks 500kg - 3T

Compliant AS1418.2
All Quality Components.
Powder Coated Finish.

Model	Size	Chain Length	Chain Size	Number of Falls	Hook Opening
EC053	500kg	3m	6mm	1	24mm
EC056	500kg	6m	6mm	1	24mm
EC13	1 Tonne	3m	6mm	1	28mm
EC16	1 Tonne	6m	6mm	1	28mm
EC23	2 Tonnes	3m	10mm	1	38mm
EC26	2 Tonnes	6m	10mm	1	38mm
EC33	3 Tonnes	3m	8mm	2	38mm
EC36	3 Tonnes	6m	8mm	2	38mm



E-SERIES Lever Blocks 250kg - 3T

Compliant AS1418.2
Single Action Directional Trigger with Neutral.
Precision Chain Alignment Guide.
Powder Coated Finish.

Model	Size	Chain Length	Chain Size	Hook Opening
EL025	250kg	1.5m	4mm	15mm
EL050	500kg	1.5m	5mm	20mm
EL075	750kg	1.5m	6mm	27mm
EL150	1.5 Tonnes	1.5m	8mm	30mm
EL300	3 Tonnes	1.5m	10mm	38mm



Chain Blocks 500kg

Compliant AS1418.2
Overload Protection Fitted.
Cast Iron Safety Latches.
Industrial Galvanised Finish.
Full Range of Spares.

Model	Size	Chain Length	Chain Size	Hook Opening
CC053	500kg	3m	5mm	20mm
CC056	500kg	6m	5mm	20mm



Lever Blocks 250kg - 500kg

Compliant AS1418.2
Wide variety of applications.
Easy to carry and easy to use.
Economical in size and price.

Model	Size	Chain Length	Chain Size	Hook Opening
CL025	250kg	1.5m	4mm	18mm
CL050	500kg	1.5m	5mm	24mm



Chain Blocks 1T - 5T

Compliant AS1418.2
Overload Protection Fitted.
Cast Iron Safety Latches.
Industrial Galvanised Finish.
Full Range of Spares.

Model	Size	Chain Length	Chain Size	Number of Falls	Hook Opening
CC13	1 Tonne	3m	6mm	1	27mm
CC16	1 Tonne	6m	6mm	1	27mm
CC23	2 Tonnes	3m	8mm	1	35mm
CC26	2 Tonnes	6m	8mm	1	35mm
CC33	3 Tonnes	3m	10mm	1	39mm
CC36	3 Tonnes	6m	10mm	1	39mm
CC53	5 Tonnes	3m	10mm	2	45mm
CC56	5 Tonnes	6m	10mm	2	45mm



Lever Blocks 750kg - 3T

Compliant AS1418.2
Overload Protection Fitted.
Cast Iron Safety Latches.
Industrial Galvanised Finish.
Full Range of Spares.

Model	Size	Chain Length	Chain Size	Hook Opening
CL075	750kg	1.5m	6mm	30mm
CL150	1.5 Tonne	1.5m	8mm	38mm
CL300	3 Tonnes	1.5m	10mm	45mm

VARIOUS MODELS WITH OPTIONAL LIFT HEIGHTS ALSO AVAILABLE

EDL - Single & Dual Speed Powered Hoist

Push Button Pendant Control.

Suits warehouse, construction, entertainment, engineering and manufacturing Industries.

Model	Load Capacity	Standard Lift	Lift Speed	Weight
Single Speed - Pendant Control Hoist				
EDL10S	100kg	3.0m	13m/min	12kg
EDL18S	180kg	3.0m	8m/min	12kg
EDL48S	480kg	3.0m	6.7m/min	21.5kg
Dual Speed - Pendant Control Hoist				
EDL10ST	100kg	3.0m	13m - 3m/min	12.5kg
EDL18ST	180kg	3.0m	8m - 3m/min	12.5kg
EDL48ST	480kg	3.0m	6.7m - 2m/min	21.5kg



EDL250

VARIOUS MODELS WITH OPTIONAL LIFT HEIGHTS ALSO AVAILABLE

EQ - Dual Speed Powered Hoist with Inverter

Adjustable Speed Inverter.

Push Button Pendant Control with Emergency Stop.

Counter Hour Meter.

IP55 Dust & Water Jet Proof Hoist Body.

40/20% Duty Rating.

No Load, High Speed Feature.

Standard 3m & 6m Lifts.

Suits mining, warehouse, construction, entertainment, engineering and manufacturing Industries.

Model	Load Capacity	Standard Lift	Lift Speed	Weight
EQ003IS	250kg	3.0m	10 - 1.7m/min	30kg
EQ005IS	500kg	3.0m	7.6 - 1.3m/min	32kg
EQ0010IS	1000kg	3.0m	7.1 - 1.2m/min	42kg
EQ003IS	250kg	6.0m	10 - 1.7m/min	32kg
EQ005IS	500kg	6.0m	7.6 - 1.3m/min	34kg
EQ0010IS	1000kg	6.0m	7.1 - 1.2m/min	46kg



EQ0010IS

ER2 - Single & Dual Speed Powered Hoist - 3 Phase

IP65 Push Button Pendant Control with Emergency Stop.

IP55 Dust & Water Jet Proof Hoist Body.

Single Speed Duty Rating - 60% ED (60min)

Dual Speed Duty Rating - 40/20% ED (30/10min)

Suits mining, warehouse, construction, entertainment, engineering and manufacturing Industries.

VARIOUS MODELS WITH OPTIONAL LIFT HEIGHTS ALSO AVAILABLE

Model	Load Capacity	Standard Lift	Lift Speed	Weight
Single Speed - 500kg - 3000kg				
ER2005L	500kg	3.0m/6.0m	3.8m/min	33kg
ER2005S	500kg	3.0m/6.0m	7.3m/min	37kg
ER2010L	1000kg	3.0m/6.0m	3.5m/min	47kg
ER2010S	1000kg	3.0m/6.0m	7.1m/min	54kg
ER2030S	3000kg	3.0m/6.0m	4.4m/min	107kg
Dual Speed - 500kg - 3000kg				
ER2005IL	500kg	3.0m	4.5m - 0.8m/min	32kg
ER2005IS	500kg	3.0m	8.5m - 1.4m/min	36kg
ER2010IL	1000kg	3.0m	4.2m - 0.7m/min	45kg
ER2010IS	1000kg	3.0m	8.2m - 1.4m/min	52kg
ER2030IS	3000kg	3.0m	5.2m - 0.9m/min	105kg



ER2010S



EW - Spring Balancer

Suitable for hanging tools, parts or welding equipment at work stations & assembly lines.
 Strong Lightweight Aluminium Body.
 Heavy Duty Top & Bottom Hook.
 Tapered Drum for exact torque retraction across the full stroke.

Model	Minimum Capacity	Maximum Capacity	Stroke	Weight
EW3	1.0kg	3.0kg	1300mm	1.4kg
EW5	2.5kg	5.0kg	1300mm	1.5kg



EWF - Spring Balancer

Suitable for hanging tools, parts or welding equipment at work stations & assembly lines.
 Strong Lightweight Aluminium Body.
 Heavy Duty Top & Bottom Hook.
 Tapered Drum for exact torque retraction across the full stroke.

Model	Minimum Capacity	Maximum Capacity	Stroke	Weight
EWF9	4.5kg	9.0kg	1300mm	3.5kg
EWF15	9.0kg	15kg	1300mm	3.8kg
EWF22	15kg	22kg	1500mm	7.0kg
EWF30	22kg	30kg	1500mm	7.6kg
EWF40	30kg	40kg	1500mm	9.8kg
EWF50	40kg	50kg	1500mm	10.2kg
EWF60	50kg	60kg	1500mm	11.6kg
EWF70	60kg	70kg	1500mm	11.9kg



ELF - Spring Balancer

Suitable for hanging tools, parts or welding equipment at work stations & assembly lines that require a longer stroke.
 2.5m Cable Lengths.
 Strong Lightweight Aluminium Body.
 Heavy Duty Top & Bottom Hook.

Model	Minimum Capacity	Maximum Capacity	Stroke	Weight
ELF3	1.5kg	3.0kg	2500mm	4.1kg
ELF5	3.0kg	5.0kg	2500mm	4.2kg
ELF9	5.0kg	9.0kg	2500mm	4.7kg
ELF15	9.0kg	15kg	2500mm	10kg
ELF22	15kg	22kg	2500mm	10.2kg
ELF30	22kg	30kg	2500mm	11kg
ELF40	30kg	40kg	2500mm	14kg
ELF50	40kg	50kg	2500mm	14.5kg
ELF60	50kg	60kg	2500mm	17kg





Single/Double Oblong Links

AS 3776 Compliant. Grade 80 Alloy Steel.

Code	Dimensions	Single	Double	W.L.L
25821	110 x 60 x 13mm	7mm	6mm	1.6T
25824	120 x 70 x 13mm	8mm	7mm	2.7T
25823	140 x 80 x 16mm	10mm	8mm	3.5T
25826	160 x 95 x 20mm	13mm	10mm	5.5T
25831	190 x 110 x 26mm	16mm	13mm	9.4T
25832	230 x 130 x 32mm	20mm	16mm	14.2T
25836	275 x 150 x 38mm	22mm	20mm	22.3T



Multi Master Oblong Links

AS 3776 Compliant.
Grade 80 Alloy Steel.

Code	Dimensions	Single/Double	W.L.L
25751A	Inside 135 x 75mm	6/7mm	3.15T
25752	Inside 160 x 90mm	7/8mm	4.25T
25753	Inside 180 x 100mm	10mm	6.7T
25754	Inside 200 x 100mm	13mm	11.2T
25755	Inside 260 x 140mm	16mm	17T
25757	Inside 350 x 190mm	20mm	26.5T



Clevis Shortening Grab Hook w/Wings

AS 3776 Compliant.
Grade 80 Alloy Steel.

Code	Description
25101	6mm Clevis Shortening Grab Hook with Wings
25102	7/8mm Clevis Shortening Grab Hook with Wings
25103	10mm Clevis Shortening Grab Hook with Wings
25104	13mm Clevis Shortening Grab Hook with Wings
25105	16mm Clevis Shortening Grab Hook with Wings
25106	20mm Clevis Shortening Grab Hook with Wings



Hammer Type Connecting Links

AS 3776 Compliant.
Grade 80 Alloy Steel.

Code	Description
25201	6mm Connecting Link (Hammer Assembly)
25203	7/8mm Connecting Link (Hammer Assembly)
25204	10mm Connecting Link (Hammer Assembly)
25205	13mm Connecting Link (Hammer Assembly)
25206	16mm Connecting Link (Hammer Assembly)
25207	20mm Connecting Link (Hammer Assembly)



Eye Type Swivel Self Locking Hook

AS 3776 Compliant.
Grade 80 Alloy Steel.

Code	Description
25041	6mm Eye Type Swivel Self Locking Hook
25042	7/8mm Eye Type Swivel Self Locking Hook
25043	10mm Eye Type Swivel Self Locking Hook
25044	13mm Eye Type Swivel Self Locking Hook
25045	16mm Eye Type Swivel Self Locking Hook
25046	20mm Eye Type Swivel Self Locking Hook



Eye Type Swivel Sling Hook with Safety Latch

AS 3776 Compliant.
Grade 80 Alloy Steel.

Code	Description
25092	7/8mm Eye Swivel Sling Hook with Safety Latch
25093	10mm Eye Swivel Sling Hook with Safety Latch
25094	13mm Eye Swivel Sling Hook with Safety Latch
25095	16mm Eye Swivel Sling Hook with Safety Latch
25096	20mm Eye Swivel Sling Hook with Safety Latch



Panel Clutch (Swift)

AS 3850 Compliant.
Grade 80 Alloy Steel.

Code	Description
25251	1 - 1.3 Tonne Panel Clutch
25252	1.5 - 2.5 Tonne Panel Clutch
25253	3 - 5 Tonne Panel Clutch
25254	6 - 10 Tonne Panel Clutch



Short Link Lifting Chain

AS 2321 Compliant.
Grade 80 Alloy Steel.

Code	Description
18300	6mm Grade 80 Short Link Lifting Chain
18301	7mm Grade 80 Short Link Lifting Chain
18302	8mm Grade 80 Short Link Lifting Chain
18304	10mm Grade 80 Short Link Lifting Chain
18307	13mm Grade 80 Short Link Lifting Chain
18310	16mm Grade 80 Short Link Lifting Chain

CUSTOM CHAIN SLINGS - MADE TO ORDER

All Slings supplied in sturdy plastic pail with your reseller information - contact info@grangelift.com.au



CRANE
LIFT WITH CONFIDENCE



Single Leg Chain Sling with Shortening Grab Hook & Self Locking Hook

AS 3775.1 Compliant.

Tested, Tagged & supplied in a storage pail with reseller details.

Code	Chain Size	Length	W.L.L
CS8MM1L1.0M	8mm	1000mm	2000kg
CS8MM1L2.0M	8mm	2000mm	2000kg
CS8MM1L3.0M	8mm	3000mm	2000kg
CS10MM1L3.0M	10mm	3000mm	3200kg

CRANE
LIFT WITH CONFIDENCE



Two Leg Chain Sling with Shortening Grab Hooks & Self Locking Hooks

AS 3775.1 Compliant.

Tested, Tagged & supplied in a storage pail with reseller details.

Code	Chain Size	Length	W.L.L
CS8MM2L2.0M	8mm	2000mm	3500kg @60°
CS8MM2L3.0M	8mm	3000mm	3500kg @60°
CS8MM2L4.0M	8mm	4000mm	3500kg @60°
CS10MM2L2.0M	10mm	2000mm	5500kg @60°
CS10MM2L3.0M	10mm	3000mm	5500kg @60°
CS10MM2L4.0M	10mm	4000mm	5500kg @60°
CS13MM2L2.0M	13mm	2000mm	9200kg @60°
CS13MM2L3.0M	13mm	3000mm	9200kg @60°

CRANE
LIFT WITH CONFIDENCE



Four Leg Chain Sling with Shortening Grab Hooks & Self Locking Hooks

AS 3775.1 Compliant.

Tested, Tagged & supplied in a storage pail with reseller details.

Code	Chain Size	Length	W.L.L
CS8MM4L3.0M	8mm	3000mm	3500kg @60°
CS8MM4L6.0M	8mm	6000mm	3500kg @60°
CS10MM4L3.0M	10mm	3000mm	5500kg @60°



Screw Pin Dee Shackle

Grade S Alloy Steel.
AS 2741 Compliant.
Other Sizes Available.

Code	Description
20901	6mm Screw Pin Dee Shackle - 500kg W.L.L
20902	8mm Screw Pin Dee Shackle - 750kg W.L.L
20903	10mm Screw Pin Dee Shackle - 1000kg W.L.L
20904	11mm Screw Pin Dee Shackle - 1500kg W.L.L
20905	13mm Screw Pin Dee Shackle - 2000kg W.L.L
20906	16mm Screw Pin Dee Shackle - 3200kg W.L.L
20907	19mm Screw Pin Dee Shackle - 4700kg W.L.L
20908	22mm Screw Pin Dee Shackle - 6500kg W.L.L



Screw Pin Bow Shackle

Grade S Alloy Steel.
AS 2741 Compliant.
Other Sizes Available.

Code	Description
20921	6mm Screw Pin Bow Shackle - 500kg W.L.L
20922	8mm Screw Pin Bow Shackle - 750kg W.L.L
20923	10mm Screw Pin Bow Shackle - 1000kg W.L.L
20924	11mm Screw Pin Bow Shackle - 1500kg W.L.L
20925	13mm Screw Pin Bow Shackle - 2000kg W.L.L
20926	16mm Screw Pin Bow Shackle - 3200kg W.L.L
20927	19mm Screw Pin Bow Shackle - 4700kg W.L.L
20928	22mm Screw Pin Bow Shackle - 6500kg W.L.L



Safety Pin Dee Shackle

Grade S Alloy Steel.
AS 2741 Compliant.
Other Sizes Available.

Code	Description
20941	13mm Safety Pin Dee Shackle - 2000kg W.L.L
20942	16mm Safety Pin Dee Shackle - 3200kg W.L.L
20943	19mm Safety Pin Dee Shackle - 4700kg W.L.L
20944	22mm Safety Pin Dee Shackle - 6500kg W.L.L
20945	25mm Safety Pin Dee Shackle - 8500kg W.L.L



Safety Pin Bow Shackle

Grade S Alloy Steel.
AS 2741 Compliant.
Other Sizes Available.

Code	Description
20961	13mm Safety Pin Bow Shackle - 2000kg W.L.L
20962	16mm Safety Pin Bow Shackle - 3200kg W.L.L
20963	19mm Safety Pin Bow Shackle - 4700kg W.L.L
20964	22mm Safety Pin Bow Shackle - 6500kg W.L.L
20965	25mm Safety Pin Bow Shackle - 8500kg W.L.L



Lifting Eyebolt

Zinc Plated.
Din580 Standard.

Code	Description
26151	6mm Zinc Plated Lifting Eyebolt - 70kg W.L.L
26152	8mm Zinc Plated Lifting Eyebolt - 140kg W.L.L
26153	10mm Zinc Plated Lifting Eyebolt - 230kg W.L.L
26154	12mm Zinc Plated Lifting Eyebolt - 340kg W.L.L
26156	16mm Zinc Plated Lifting Eyebolt - 700kg W.L.L
26158	20mm Zinc Plated Lifting Eyebolt - 1200kg W.L.L
26159	22mm Zinc Plated Lifting Eyebolt - 1500kg W.L.L
26160	24mm Zinc Plated Lifting Eyebolt - 1800kg W.L.L



Lifting Eyenut

Zinc Plated.
Din582 Standard.

Code	Description
26201	6mm Zinc Plated Lifting Eyenut - 70kg W.L.L
26202	8mm Zinc Plated Lifting Eyenut - 140kg W.L.L
26203	10mm Zinc Plated Lifting Eyenut - 230kg W.L.L
26204	12mm Zinc Plated Lifting Eyenut - 340kg W.L.L
26206	16mm Zinc Plated Lifting Eyenut - 700kg W.L.L
26208	20mm Zinc Plated Lifting Eyenut - 1200kg W.L.L
26209	22mm Zinc Plated Lifting Eyenut - 1500kg W.L.L
26210	24mm Zinc Plated Lifting Eyenut - 1800kg W.L.L

CRANE
LIFT WITH CONFIDENCE



Ratchet Tie Down

AS 4380 Compliant.
Heavy Duty Ratchet Buckle.
Heavy Duty Hook and Keeper.

Code	Size	Length	Pack Qty	Lashing Capacity
GLR255	25mm	5m	25	750kg
GLR356	35mm	6m	10	1500kg
GLR509	50mm	9m	5	2500kg
GLR759	75mm	9m	4	5000kg
GLR5013	50mm	13m	5	2500kg

CRANE
LIFT WITH CONFIDENCE



Replacement Strap

AS 4380 Compliant.
Heavy Duty Hook and Keeper.

Code	Size	Length	Pack Qty	Lashing Capacity
GLS5009	50mm	9m	10	2500kg
GLS5011	50mm	11m	10	2500kg
GLS5013	50mm	13m	10	2500kg

CRANE
LIFT WITH CONFIDENCE



Cam Buckle Tie Down

AS 4380 Compliant.
Comes in a pack of two.
Black 'S' Hooks at each end.

Code	Size	Length	Pack Qty	Lashing Capacity
GLCS252	25mm	2m	24	250kg

CRANE
LIFT WITH CONFIDENCE



ASD10 Aluminium Cargo Bar

One-Piece Aluminium Tubing with Articulating Foot Pads.
Secures and helps keep load from shifting and falling in transit.
Use between walls or floor and roof of van, truck, trailer or rail car.
Push against load, extend bar to suit and lock in place to secure load.

Features	Specifications
Range	2200 - 2610mm
Construction	Aluminium Round Tube



ASD20 Steel Cargo Bar

38mm Two-Piece Square Steel Tubing with Articulating Rubber Foot Pads.
Mechanical Ratchet Operation ensures Cargo Bar will not slip or vibrate loose.
Ideal for wet or freezing conditions.
Two-Piece Hinged Bar can be folded and easily stored in trailer cab.

Features	Specifications
Range	2200 - 2920mm
Construction	Steel Square Tube

WARNING:
Grade 70 Must not be used for lifting purposes.



Grade 70 Transport Chain

AS 4344 Compliant.

Code	Chain Size	Lashing Capacity	Metres per Pail
GL70C06	6mm	2300kg	62.5m
GL70C08	8mm	3800kg	35m
GL70C10	10mm	6000kg	22.5m
GL70C13	13mm	9000kg	13.4m



Grade 70 Load Restraint Kit

AS 4344 Compliant.
Winged Grab Hooks at each end.
Gold Zinc Plated.
Reusable Plastic Carry Case.

Code	Chain Size	Length	Lashing Capacity
GL70K086	8mm	6m	2300kg
GL70K089	8mm	9m	3800kg
GL70K106	10mm	6m	6000kg
GL70K109	10mm	9m	9000kg



Grade 70 Clevis Grab Hook

AS 4344 Compliant.
Winged Grab Hook.
Gold Zinc Plated.

Code	Size	Lashing Capacity
GL70H06	6mm	2300kg
GL70H08	7/8mm	3800kg
GL70H10	10mm	6000kg
GL70H13	13mm	9000kg



Grade 70 Clevis Slip Hook

AS 4344 Compliant.
Gold Zinc Plated.

Code	Size	Lashing Capacity
GL70S06	6mm	2300kg
GL70S08	7/8mm	3800kg
GL70S10	10mm	6000kg
GL70S13	13mm	9000kg



Grade 70 Clevis Lug Link

AS 4344 Compliant.
Gold Zinc Plated.

Code	Size	Lashing Capacity
GL70L08	7/8mm	3800kg
GL70L10	10mm	6000kg
GL70L13	13mm	9000kg



Loadbinder Ratchet

AS 4344 Compliant.
Winged Hooks.
Manufactured from Dropped Forged Steel.

Part No.	Size	Lashing Capacity
GL70RL06	6mm	2300kg
GL70RL08	7/8mm	3800kg
GL70RL10	10mm	6000kg
GL70RL13	13mm	9000kg



Loadbinder Lever

AS 4344 Compliant.
Winged Hooks.
Manufactured from Dropped Forged Steel.

Part No.	Size	Lashing Capacity
GL70LL06	6mm	2300kg
GL70LL08	7/8mm	3800kg
GL70LL10	10mm	6000kg
GL70LL13	13mm	9000kg



Team Systems commitment to its products is supported with a full range of replacement parts.

We maintain a complete inventory of spare parts for our lifting and handling equipment direct from the manufacturer. All parts are genuine replacement original equipment ensuring that the continued high level performance of the equipment is sustained.

- SPARTS PARTS AVAILABLE FOR:**
- PALLET TRUCKS
 - SCISSOR LIFT & PLATFORMS
 - MANUAL HAND STACKERS & PLATFORM STACKERS
 - ELECTRIC STACKERS & POWER PALLET TRUCKS



- Poly on Cast Iron Wheels • Nylon Wheels
- Bearings • Handles • Pumps • Springs
- Axles & Frame Rollers • Safety Valves



- Wheels • Lowering Cables • Bearings
- Handles • Pumps • Rollers

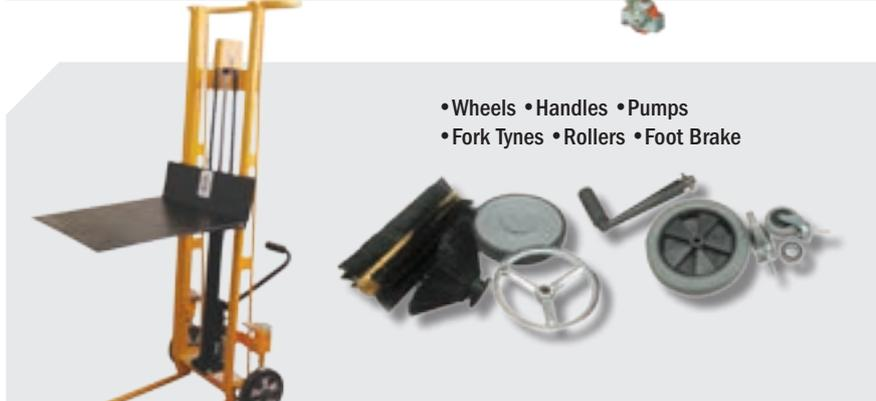

- Wheels • Handles • Pumps
- Fork Tynes • Rollers • Foot Brake



- Drive Wheel • Drive Motor
- Handles • Switches • Batteries

DRUM HANDLING & STORAGE



Drumtech Hydraulic Drum Lifters.....	76
Drumtech Drum Lifters & Carriers	77-78
Bulk Drum Storage Systems.....	79
Bund Covers, Drum Storage Systems	80





**NF10
Tilting Drum Stand - 170kg Capacity**

Tilting drum stands are virtually self-loading as drums can be loaded and transported by one man, without him touching the drum. They expedite the easy handling of large and small drums.

Castors with nylon wheels provide smooth movement and easy positioning of stands. When stand is in the horizontal position, handles can be retracted. Plastic hand grips resist slipping when drums are being loaded or transported.



**TSD44
Drum Dolly**

To suit 205 Litre/44 Gallon Drum.
614mm Diameter.
Smooth Rolling and Strong, Durable Construction.
80mm Diameter Heavy Duty Castors.
Optional 100mm Castors Available.



**CAC45
Hydraulic Loader/Unloader**

Lift steel drums on and off a pallet.

Features	Specifications
Capacity	450kg
Drum Capacity	210 Litres
Lift Height	300mm
Weight	165kg



Attach drum to unit.



Raise drum using foot pump.



Tip using crank operated gearbox.

**NBF35
Tilting Barrel**

Handles steel drums without complicated adjustments or exchanging attachments.
Drums are raised & transported simply by engaging the screw operated rim clamp.
Hydraulic Foot Operated Pump raises drum.
180 Degree Rotation.
Suits Steel Drums up to 205 Litres.



Features	Specifications
Capacity	350kg
Lift Height	1425mm
Dimensions	1190 x 890 x 2020mm
Weight	155kg



**ZG350
Drum Puller**

All Steel Construction.
Easily moves closed drums.
Works with shop crane, hoist or forklift hooks.

Model	Capacity	Size	Weight
ZG350	350kg	210 Litres	6kg



**ZG500
Drum Puller**

All Steel Construction.
Easily moves closed drums.
Works with shop crane, hoist or forklift hooks.

Model	Capacity	Size	Weight
ZG500	500kg	210 Litres	9kg



**CDA20
Drum Racking**

Features	Specifications
Capacity	250kg x 2/550kg x 2
Drum Capacity	210 Litres
Weight	35/77kg



**NG10 Single
Drum Lifting Clamp**

Simple mechanical forklift attachment for safely lifting 205 litre steel drums.
Automatic operation for picking-up and releasing 205 litre steel drums.



**CDB10
Aluminium Hand Operated
Rotation Pump**

Consists of Pump & 3 Piece Aluminium Submersion Rod.
Suitable for Petrol, Coal Oil, Diesel Oil & Edible Oils etc.

Features	Specifications
Inlet Size	25mm
Outlet Size	19mm
Oil Transfer	382/min



**NGA360A
Single Drum Lifter**

Features	Specifications
Capacity	360kg
Drum Capacity	205 Litres
Fork Opening	560mm
Overall Size	880 x 710 x 1000mm
Weight	60kg

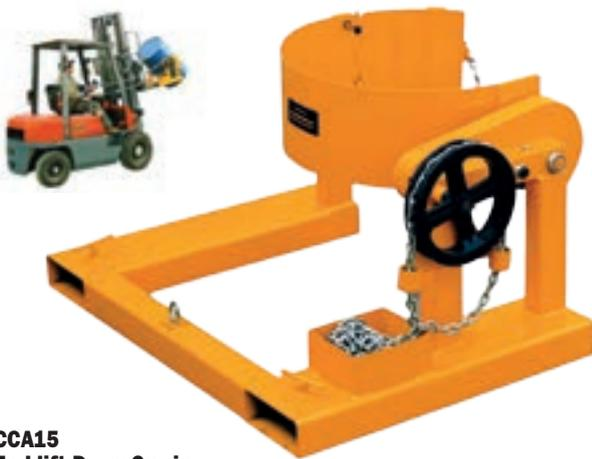

**CCA15
Forklift Drum Carrier**

Converts your forklift into a drum handler.
Allows you to easily lift, transport, raise and tilt loaded drums.
The 10' pull-chain loop allows control from the driver's seat.

Features	Specifications
Capacity	350kg Steel Drum
Drum Capacity	210 Litres
Fork Opening	620mm Apart
Fork Pocket	65 x 180mm (H x W)
Weight	70kg



**CCK41
SELF LOCK DRUM LIFTER**

Works easily with overhead hoist or forklift hook.



**CCK21
Drum Lifter**

3 Point Contact Lifting Arms.
Prevents or minimises deformation of the open head drum.
Suitable for both open head and closed head drums up to 350kg.
Automatically engages drum rim when raising drum.

Features	CCK21	CCK41
Capacity	350kg	500kg
Drum Capacity	125/210 Litres	132 Litres
Drum Type	Plastic & Steel Drums	Plastic & Steel Drums
Weight	7kg	10kg



**DB2G
Two Drum Spill Bund**

Store 2 x 205L, 20L or 60L Drums to capture leaks, drips and spills.
Australian Made.

Features	Specifications
Capacity	246 Litres
Dimensions	1240 x 640 x 510mm
Weight	25kg



**DB4G
Four Drum Spill Bund**

Store 4 x 205L to capture leaks, drips and spills.
Removable Grate.
Australian Made.

Features	Specifications
Capacity	242 Litres
Dimensions	1230 x 1230 x 280mm
Weight	31kg



**DB2LP
Two Drum Spill Bund - Low Profile**

Store 20L & 60L Drums, Batteries etc to capture leaks, drips and spills.
Units can be connected with a simple bund to bund connector, which will increase the bund capacity. Also available is an optional ramp.
Australian Made.

Features	Specifications
Capacity	83 Litres
Dimensions	1220 x 610 x 150mm
Weight	16kg



**DB4LP
Four Drum Spill Bund - Low Profile**

Store 20L & 60L Drums, Batteries etc to capture leaks, drips and spills.
Units can be connected with a simple bund to bund connector, which will increase the bund capacity. Also available is an optional ramp.
Australian Made.

Features	Specifications
Capacity	145 Litres
Dimensions	1210 x 1210 x 150mm
Weight	29kg



**DB6LP
Six Drum Spill Bund - Low Profile**

Store 6 x 205L Drums to capture leaks, drips and spills.
Units can be connected with a simple bund to bund connector, which will increase the bund capacity. Also available is an optional ramp.
Australian Made.

Features	Specifications
Capacity	240 Litres
Dimensions	1820 x 1220 x 150mm
Weight	45kg



**DB8LP
Eight Drum Spill Bund**

Store 8 x 205L Drums to capture leaks, drips and spills.
Units can be connected with a simple bund to bund connector, which will increase the bund capacity. Also available is an optional ramp.
Australian Made.

Features	Specifications
Capacity	270 Litres
Dimensions	2420 x 1210 x 150mm
Weight	59kg



DBSIBC IBC Bund

Store 1000L IBC to prevent and capture leaks, drips and spills.
Removable Grates.
2000kg UDL.
Australian Made.

Features	Specifications
Capacity	1150 Litres
Dimensions	1900 x 1500 x 750mm
Weight	96kg



DBDIBC Twin IBC Bund

Store 2 x 1000L IBC to prevent and capture leaks, drips and spills.
Removable Grates.
3600kg UDL.
Australian Made.

Features	Specifications
Capacity	1470 Litres
Dimensions	2600 x 1480 x 660mm
Weight	142kg



HTDB1150 Hard Top Cover to suit DB1150G

Polyethylene Enclosure ONLY to suit the DB1150G IBC Bund.
Used to protect the IBC from contamination and unauthorised access.
Lockable Two-Way Access Roller Doors with Heavy Duty Internal Steel Frame.
Australian Made.

Features	Specifications
Capacity	To suit DBSIBC IBC Bund ONLY
Overall Dimensions	1980 x 1600 x 1930mm
Flat Packed	Onsite assembly required



DBPRO Spill Crew Pedestrian Ramp

Convenient Anti-Slip Ramp that allows operators to safely and easily access gutters and small steps.
Australian Made.

Features	Specifications
Colour	Orange
Dimensions	1220 x 750 x 110mm
Construction	Polyethylene



SCDHPEY007 Document Storage Holder

Store Material Safety Data Sheets, Instruction Sheets and other important documents safely on site.
Includes relevant Adhesive Labels.

Features	Specifications
Colour	Hi Vis Yellow
Dimensions	318 x 260 x 57mm
Construction	Polyethylene



ACCESSORIES

DBC Drum Bund Connector

Join Spill Crew Low Profile Drum Bund Sumps together.
25mm Threaded Tank Flange with Double Gasket.



DBLPJS1793 Drum Bund Joiner Strip - 1793mm

Join Spill Crew Low Profile Drum Bund Bunds together.
1793mm 'Push On' Joiner Strip.



DBLPJS1183 Drum Bund Joiner Strip - 1183mm

Join Spill Crew Low Profile Drum Bund Bunds together.
1183mm 'Push On' Joiner Strip.



SAFETY EQUIPMENT & SIGNAGE

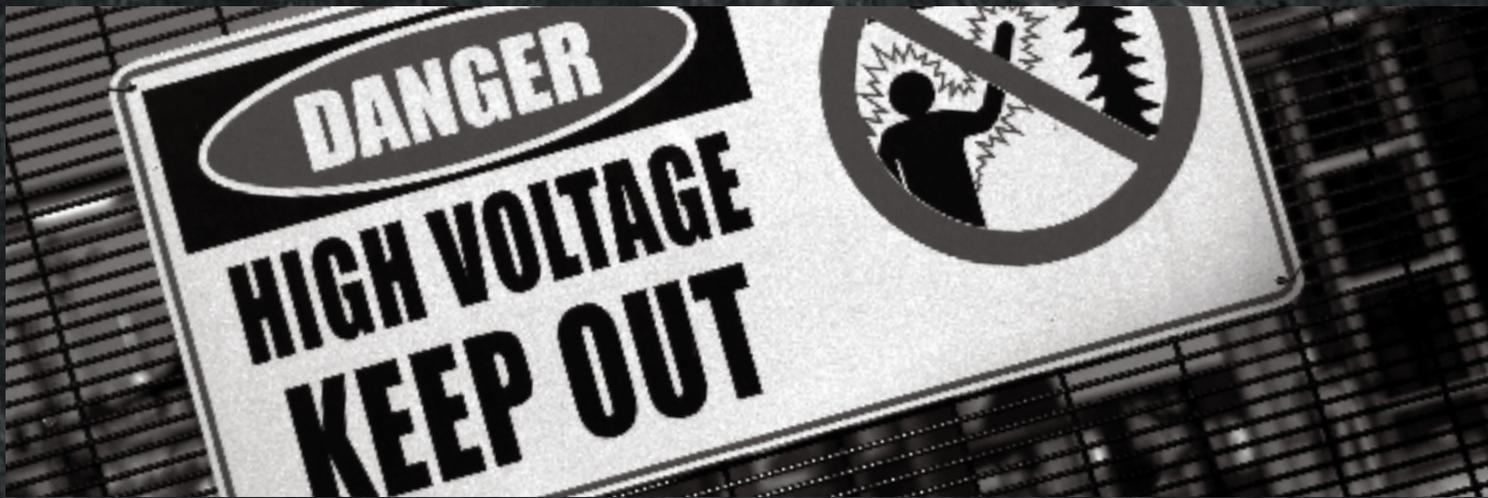

Workplace Safety	82
Convex Mirrors	83
Portable Barriers	84
Spill Kits	85
Bollards & Protection Guards	86-87
Floor Matting	88-89
Dangerous Goods Storage	90-91
Safety Signs & Tags	92-93
Impact Protection Bumpers	94





LMSOLO SOLO LIFT PRO

The Solo Lift Pro allows a box to be lifted and carried with only one hand!
Leaves one hand free to open doors, press elevator buttons or hold handrails.
Solo Lift Pro helps prevent:

- Risk of low back strain
- Need to bend Lumbar spine
- Won't strain trying get under box for lifting
- Won't twist/overstretch while placing boxes

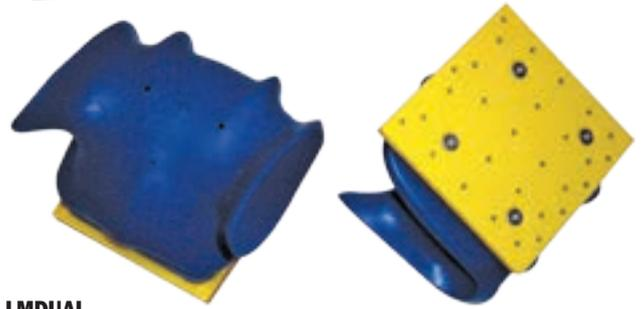

LMDUAL DUAL LIFT

The Dual Lift adds "handles" to any box.
Suitable for lifting heavy boxes up to to 45kg.
There's no need to tilt your shoulders or twist your spine just to get your fingers under the box so you can lift it.
Simply attach the Dual Lift handles onto the box and lift with your legs.



BTC Reflective Cones

Ideal for roadworks, civil engineering, schools and carparks etc.
Available in 3 Standard Sizes.
Come standard with Reflective Collars.
Durable one piece construction to both 450 and 700mm models.
1000mm model features 7kg base and large footprint for increased stability.
Suitable for Indoor or Outdoor use.
U.V. Stabilised to minimise fading.
Retractable Cone Bar to suit also available.

Model	Description
BTC450R	Fluoro Cone with Reflective Sleeve 450mm High
BTC700R	Fluoro Cone with Reflective Sleeve 700mm High
BTC1000R	Fluoro Cone with Reflective Sleeve 1000mm High
RCB2	Retractable Cone Bar 1.2 to 2 metres Long

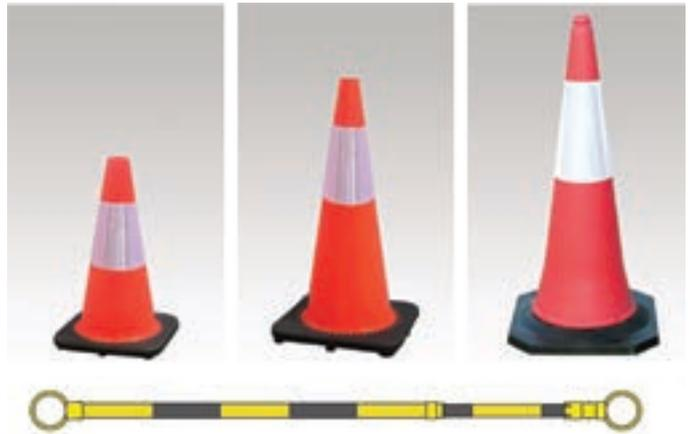

MANUAL SWING GATES

Manually Operated Swing Gates.
Can be mounted to Bollards or any Solid Surface.
Standard 5m Rail can be cut down to any length.
Aluminium Rail includes Hi-Vis Reflective Panel.
Includes Gate Receiver for Wall or Post Mounting.
Round or Square Bollards available on request.
Optional Steel Bollards, Receiver Posts and Wall Receivers are available on request.

Features	Specifications
Description	Manual Pedestrian or Vehicle Gate
Material	Galvanised Steel Assembly with Aluminium Rail
Rail Type	Aluminium Extrusion 145 x 40 x 5000mm
Gate Swing	Upto 180 Degrees
Gate Stop	Optional Receiver Post or Wall Receiver
Opening	5 metres Maximum - 2 metres Minimum
Height	1000mm
Mounting	Post or Wall
Weight	35kg Gate Assembly with 5m Rail

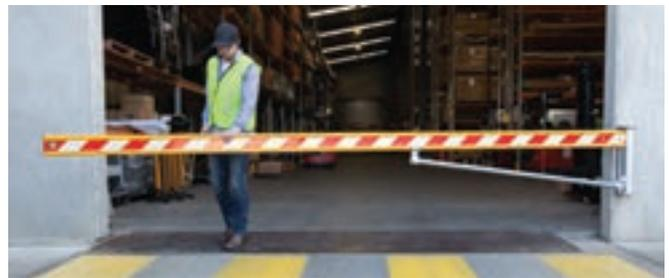

Part No.	Description
MSG5000	Manual 5m Swing Gate (Bollard not included)
C90SM	Surface Mount Round Bollard - 90 x 5 x 1000mm
C90BG	Below Ground Round Bollard - 90 x 5 x 1380mm
C140SM	Surface Mount Round Bollard - 140 x 5 x 1200mm
C140BG	Below Ground Round Bollard - 140 x 5 x 1700mm
MSGRK	Additional Gate Receiver Kit

CONVEX MIRRORS - OUTDOOR

An extremely durable weather-proof mirror suitable for road and pedestrian traffic applications, distribution depots and parking areas. Unbreakable polycarbonate face with high visibility orange visor.

All of these mirrors come complete with both wall mount brackets and post mount brackets to suit a 60mm diameter post. Additional 60mm wall mount brackets are available if required.

Weather Proof Unbreakable Polycarbonate Face.

Comes standard with both wall and post mounting brackets.

Additional 60mm Wall Mount Brackets are available if required.

Model	Description
MC4500D	450mm Outdoor Convex Mirror
MC6000D	600mm Outdoor Convex Mirror
CAP60	Galvanised Post Cap to suit 60mm Sign Post
MCB60	Wall Mount Bracket for MC450/600



Wall mount bracket.



CONVEX MIRRORS - INDOOR

All of these mirrors come complete with both wall mount brackets and post mount brackets to suit a 60mm diameter post.

Unbreakable Polycarbonate Face.

Fully Adjustable to any angle.

Extends field of view over a broad area.

Supplied with Wall & Post Mount Brackets.

Suits 60mm Diameter Posts.

Additional 60mm Wall Mount Brackets are available if required.

Model	Description
MC300ID	300mm Indoor Convex Mirror
MC450ID	450mm Indoor Convex Mirror
MC600ID	600mm Indoor Convex Mirror
MC800ID	800mm Indoor Convex Mirror



Wall mount bracket.

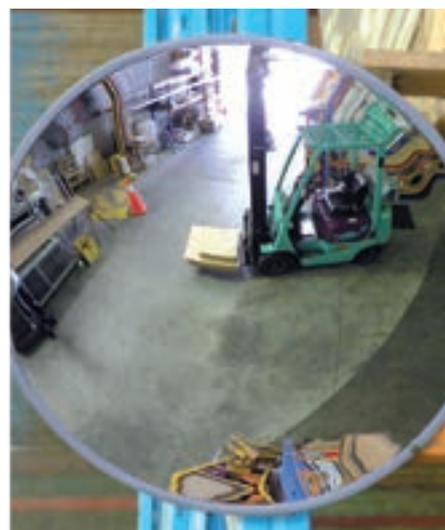

CONVEX MIRRORS - INDOOR DOME

Full, Half or Corner Domes available.

An economical, lightweight alternative for general surveillance of a broad area.

Full Domes may be suspended on chains or fixed directly to the ceiling to provide a 360° view.

Half Domes provide a 180° view and corner domes provides a 90° view.

Lightweight & simple mounting.

Unbreakable Polycarbonate Face.

No maintenance required.

Model	Description
D60360	600mm Dome Mirror
D60180	600mm Half Dome Mirror
D6090	600mm Corner Dome Mirror



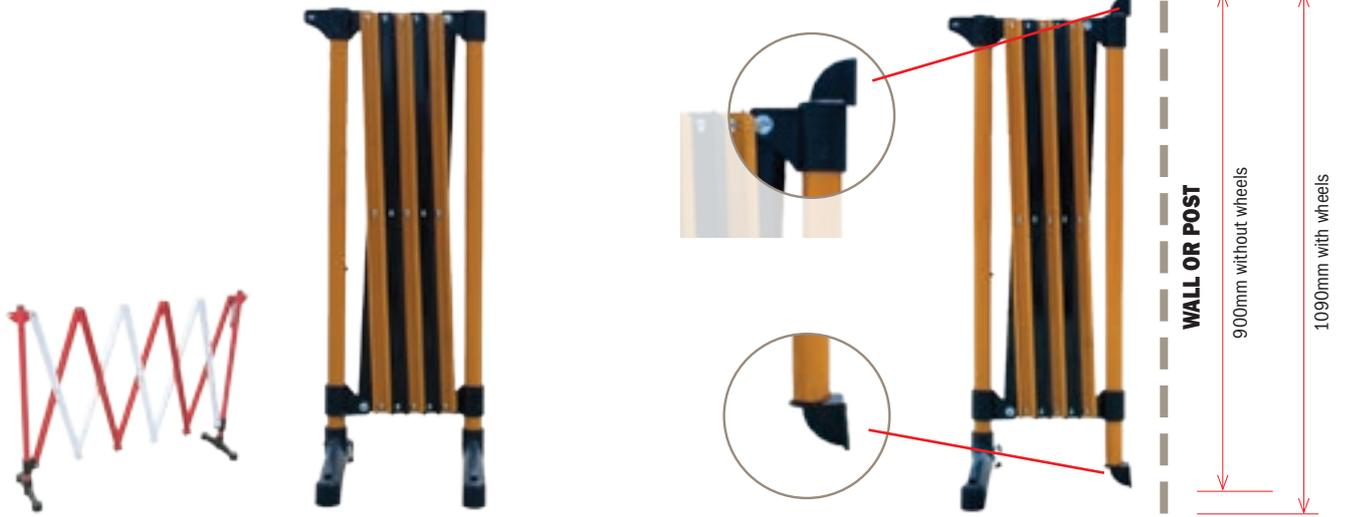

BPG300BY - Freestanding PORT-A-GUARD - Standard 3m
 Port-a-guard is a portable, expanding crowd control barrier.
 Suitable for indoor or outdoor use.

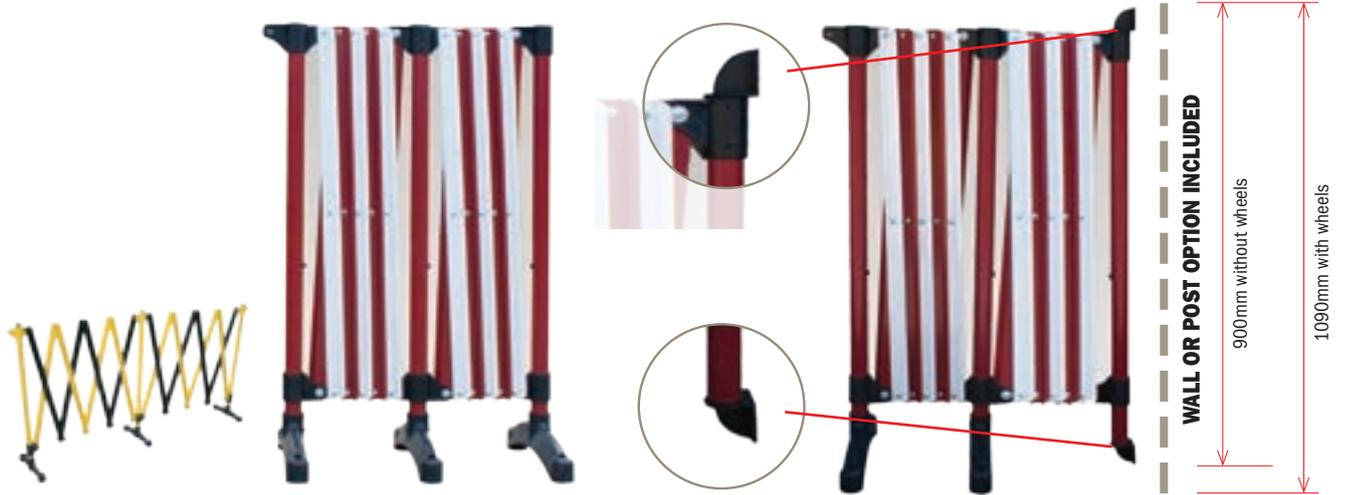

BPG600RW - Freestanding PORT-A-GUARD - Standard 6m
 Port-a-guard is a portable, expanding crowd control barrier.
 Suitable for indoor or outdoor use.



BPGM140 PORT-A-GUARD MAXI Standard 6.7m
 A combination of aluminium slats, galvanised slide components and stainless steel fixings means the Maxi is suitable for both indoor and outdoor applications.
 Complete with four heavy dutylocking castors.
 Can be linked together to form a continuous barrier.

Model	Description
BPGM140	Port-a-Guard Expanding Barrier 1430mm x 6.7m
BPGMWR	Wall Receiver Bracket for BPGM140
BPGM180	Port-a-Guard Expanding Barrier 1800mm x 7.8m

**SKGPPP - 40L Universal Spill Kit**

- 4 x 1200 x 75mm General Purpose Boom
 - 12 x 410 x 510mm General Purpose Pads
 - 2 x 140 x 500mm Contaminated Waste Disposal Bag
 - 1 Pair x 450mm PVC Gloves
 - 1 x Spill Kit Laminated Instructions
 - 1 x Blue Waterproof Labelled PVC Bag
- Australian Made.

**SKGPGU120 - 130L Universal Spill Kit**

- 1 x 120L Blue Labelled Wheelie Bin
 - 4 x 1200 x 75mm General Purpose Boom
 - 50 x 410 x 510mm General Purpose Pads
 - 2 x 10kg Ultrasorb General Purpose Absorbent Bag
 - 4 x 140 x 500mm Contaminated Waste Disposal Bag
 - 50 x Global All Purpose Wipes
 - 1 Pair x 450mm PVC Gloves
 - 1 x Spill Kit Laminated Instructions
 - 1 x General Purpose Front Label
 - 2 x General Purpose Side Label
 - 1 x PVC Wheelie Bin Instruction Sheet Holder
 - 1 x Audit Tag Single
 - 1 x 50m x 75mm Yellow/Black Caution/Spill Tape
- Australian Made.

**SKGPGU240 - 247L Universal Spill Kit**

- 1 x 240L Blue Labelled Wheelie Bin
 - 6 x 1200 x 75mm General Purpose Boom
 - 100 x 410 x 510mm General Purpose Pads
 - 4 x 10kg Ultrasorb General Purpose Absorbent Bag
 - 8 x 140 x 500mm Contaminated Waste Disposal Bag
 - 50 x Global All Purpose Wipes
 - 1 Pair x 450mm PVC Gloves
 - 1 x Spill Kit Laminated Instructions
 - 1 x General Purpose Front Label
 - 2 x General Purpose Side Label
 - 1 x PVC Wheelie Bin Instruction Sheet Holder
 - 1 x Audit Tag Single
 - 1 x 50m x 75mm Yellow/Black Caution/Spill Tape
- Australian Made.

**SKHET - 37L Oil & Fuel Spill Kit**

- 1 x 340 x 220mm Oil & Fuel Pillow
 - 10 x 450 x 450mm Absorbent Pads
 - 1 x 8L Global Peat Bag
 - 1 x 140 x 500mm Contaminated Waste Disposal Bag
 - 1 x 2400 x 750mm Absorbent Mini Boom
 - 1 Pair x 450mm PVC Gloves
 - 1 x Spill Kit Laminated Instructions
 - 1 x Yellow Waterproof Labelled PVC Bag
- Australian Made.

**SKHGP120 - 135L Oil & Fuel Spill Kit**

- 1 x 120L Yellow Labelled Wheelie Bin
 - 1 x 2.4m x 100mm Absorbent Mini Boom
 - 2 x 1200 x 100mm Absorbent Mini Boom
 - 50 x 450 x 450mm Absorbent Pads
 - 2 x 28L Global Peat Bags
 - 4 x 140 x 500mm Contaminated Waste Disposal Bag
 - 1 Pair x 450mm PVC Gloves
 - 1 x Spill Kit Laminated Instructions
 - 1 x General Purpose Front Label
 - 2 x General Purpose Side Label
 - 1 x PVC Wheelie Bin Instruction Sheet Holder
 - 1 x Audit Tag Single
 - 1 x 50m x 75mm Yellow/Black Caution/Spill Tape
- Australian Made.

**SKHGP240 - 235L Oil & Fuel Spill Kit**

- 1 x 240L Yellow Labelled Wheelie Bin
 - 2 x 2.4m x 100mm Absorbent Mini Boom
 - 4 x 1200 x 100mm Absorbent Mini Boom
 - 50 x 450 x 450mm Absorbent Pads
 - 4 x 28L Global Peat Bags
 - 6 x 140 x 500mm Contaminated Waste Disposal Bag
 - 1 Pair x 450mm PVC Gloves
 - 1 x Spill Kit Laminated Instructions
 - 1 x General Purpose Front Label
 - 2 x General Purpose Side Label
 - 1 x PVC Wheelie Bin Instruction Sheet Holder
 - 1 x Audit Tag Single
 - 1 x 50m x 75mm Yellow/Black Caution/Spill Tape
- Australian Made.

**SKCET - 35L Hazchem Spill Kit**

- 3 x 1200 x 75mm General Purpose Boom
 - 20 x 450 x 450mm Absorbent Pads
 - 1 Pair x 450mm PVC Gloves
 - 1 x Spill Kit Laminated Instructions
 - 1 x Red Waterproof Labelled PVC Bag
- Australian Made.

**SKC120V - 78L Hazchem Spill Kit**

- 1 x 120L Red Labelled Wheelie Bin
 - 2 x 2.4m x 75mm Absorbent Mini Boom
 - 50 x 450 x 450mm Absorbent Pads
 - 1 x 30L Multisorb Vermiculite Bags
 - 4 x 140 x 500mm Contaminated Waste Disposal Bag
 - 1 Pair x 450mm PVC Gloves
 - 1 x Spill Kit Laminated Instructions
 - 1 x General Purpose Front Label
 - 2 x General Purpose Side Label
 - 1 x PVC Wheelie Bin Instruction Sheet Holder
 - 1 x Audit Tag Single
 - 1 x 50m x 75mm Yellow/Black Caution/Spill Tape
- Australian Made.

**SKC240V - 150L Hazchem Spill Kit**

- 1 x 120L Red Labelled Wheelie Bin
 - 4 x 2.4m x 75mm Absorbent Mini Boom
 - 100 x 450 x 450mm Absorbent Pads
 - 2 x 30L Multisorb Vermiculite Bags
 - 8 x 140 x 500mm Contaminated Waste Disposal Bag
 - 1 Pair x 450mm PVC Gloves
 - 1 x Spill Kit Laminated Instructions
 - 1 x General Purpose Front Label
 - 2 x General Purpose Side Label
 - 1 x PVC Wheelie Bin Instruction Sheet Holder
 - 1 x Audit Tag Single
 - 1 x 50m x 75mm Yellow/Black Caution/Spill Tape
- Australian Made.

SAFETY BOLLARDS

Ideal for protecting expensive equipment such as drill presses, lathes & saws from possible fork truck damage. Can be used both indoors and outdoors to protect work areas.



W170
High Profile Guard

Features	Specifications
Height	1067mm
Length	1220mm
Plate Size	200 x 200mm
Pipe Size	110mm
Weight	29.5kg



W178
Low Profile Guard

Features	Specifications
Height	228mm
Length	1220mm
Plate Size	200 x 200mm
Pipe Size	115mm
Weight	16kg

W145
Safety Bollard

Ideal for protecting expensive equipment such as drill presses, lathes and saws from possible fork truck damage. Can be used both indoors and outdoors to protect walkways.

Features	Specifications
Height	915mm
Plate Size	200 x 200mm
Pipe Size	110mm
Weight	10.5kg



MACHINERY GUARD RAILS

TSC514/TSC518
Machinery Guard Rails

Protects machinery & equipment from damage.
Powder Coated UV Finish.
Easy Bolt-on Installation Design.
Light Emitting Warning Tape Film for high visibility in low light applications.

Features	TSC514	TSC518
Height	1000mm	1000mm
Length	1000mm	1500mm
Tube Diameter	40mm	40mm
Colour	Black/Yellow	Black/Yellow



**BDB500C - Bull Dog Bracket
Corner Pallet Racking Leg Guard**

Complies with AS4084-2012.

Designed for corner applications.

Powder Coated High Visibility Safety Yellow.

Supplied with all fixings.

Mounted independently to avoid impact transference.



Model	Description	Construction
BDB500C	180 x 180 x 500mm	6mm Thick Mild Steel

**BDB - Bull Dog Bracket
Pallet Racking Leg Guard**

Pallet racking legs are often supporting many tonnes of product.

Protecting these legs is of vital importance to avoid potential disasters caused as a result of impact by forklifts or trolleys.

Four Bolt Fixing for maximum security.

Powder Coated High Visibility Safety Yellow.

Protects your investment and reduces the risk of collapse due to impact.

Comes complete with fixings.

Mounted independently of racking to avoid impact transference.



Model	Description	Installation
BDB	400mm x 5mm Laser Cut Plate	4 x 12mm Masonry Anchors
BDB500	500mm x 6mm Laser Cut Plate	4 x 12mm Masonry Anchors



**7.6m Retracta-Belt
Wall Mount**

Permanent Installation Design.

Belt extends from 0-7.6 metres

High Impact Polycarbonate Housing.

All fixings and wall receiver end included.

Model	Description	Length
RWM76BYD	Retracta-Belt Wall Mount - Black/Yellow	7.6m
RWM76RD	Retracta-Belt Wall Mount - Red	7.6m
RWM76YW	Retracta-Belt Wall Mount - Yellow	7.6m
RWM76BK	Retracta-Belt Wall Mount - Black	7.6m



**7.6m Retracta-Belt
Magna Mount**

Quickly reposition to suit your particular application.

Safety Bungy prevents damage if Magna-mount is accidentally dislodged.

Powder Coated Aluminium Housing.

Complete with Magnetic Base & Belt Clip.

Model	Description	Length
RMM76BYD	Retracta-Belt Magna Mount - Black/Yellow	7.6m
RMM76RD	Retracta-Belt Magna Mount - Red	7.6m
RMM76YW	Retracta-Belt Magna Mount - Yellow	7.6m
RMM76BK	Retracta-Belt Magna Mount - Black	7.6m



**9m Retractable
Tape Barrier**

Fits over your Cone or Post.

4 Way Connectivity.

Push Button Tape Lock.

Model	Description	Length
SKIPRW	Retractable Barrier - Red/White	9m
SKIPBY	Retractable Barrier - Black/Yellow	9m
SKBELTBY	Replacement Belt - Black/Yellow	9m
SKBELTRW	Replacement Belt - Red/White	9m



Plastic Chain - 100% Recyclable

A high strength plastic safety and barrier chain which can be used to cordon off work place and public access areas.

Model	Description
PC6YR	Plastic Safety Chain - 6mm Yellow per 25 metre roll
PC6RWR	Plastic Safety Chain - 6mm Red/White per 25 metre roll



ENTRY MASTER - High Traffic Mat

Attractive, Hard Wearing Mat for high traffic areas.
All Weather Design suitable for indoor/outdoor use.
Raised Rubber Border helps trap moisture & dirt.
Grippers on underside.
Various Colours available.

Sizes:
600 x 900mm
900 x 1500mm
1200 x 1800mm



DIAMOND PLATE SPONGE 416 - Industrial Mat

Slip resistant, hard wearing & chemical resistant.
Resilient sponge base to enhance comfort.
Yellow Safety Borders.
Ideal for all dry areas including warehouses & workstations.
Will not delaminate.

Sizes:
600 x 900mm
900 x 1500mm
900mm runner
1200mm runner



MULTIGUARD 220

A durable rubber dirt barrier entrance mat.
Hundreds of vertical rubber fingers push into shoe treads to remove mud, moisture, snow, sand, dirt & leaves.
Easily cleaned by hose, high pressure cleaner or simply by shaking.
Anti-slip backing & an integrated bevelled anti-trip edging.

Sizes:
600 x 800mm
800 x 1000mm
900 x 1800mm

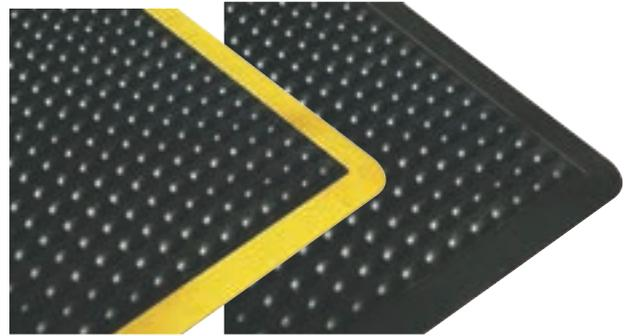

ERGO STANCE 310 - Anti Fatigue Mat

Ergonomically Designed Domed Surface to improve circulation & give maximum comfort to relieve the strain of constant standing.
Ideal for checkouts, workstations and counters.
100% Natural Rubber.
Optional Yellow Safety Edge available.

Sizes:
600 x 900mm
900 x 1200mm
900mm Runner
1200mm Runner



DECOR PLUSH 512 - Medium Traffic Mat

Absorbs water & dirt from shoes.
Hides dirt & water.
Attractive smooth surface
Easy to clean & dries quickly.
Solution dyed to prevent fading.

Sizes:
600 x 900mm
900 x 1500mm
900mm Runner

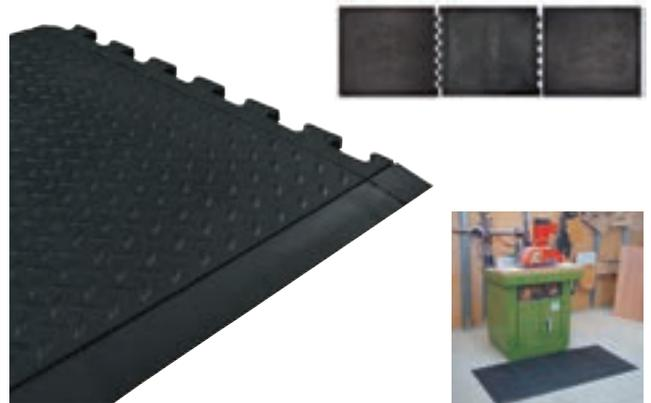

COMFORT ZONE - Anti Fatigue Mat

Versatile & Economical Anti-Fatigue System.
Centres & ends available for continuous runs.
Suitable for light trolleys.
Slip Resistant Chequer Plate Pattern
Ideal for counters, workstations & production lines.

Tile Size:
710 x 780mm



INDUSTRIAL MAT 825 - Extreme Heavy Duty Mat

Drainage holes for water & debris
 Bevelled edges for safety
 Available in Nitrile red for extra oil resistance
 Ideal for kitchens or workshops

Sizes:
 900 x 1500mm
 900 x 3000mm
 900 x 4500mm
 Thickness 14mm



CHAIRMAT 300

Clear vinyl mat with anchors on back
 Protects carpet from chairs and castors
 Available without anchors for hard floors (300H)
 2 Year Warranty
 Available in Polycarbonate with 6 Year Warranty

Sizes:
 900 x 1200mm
 1100 x 1350mm
 1200 x 1500mm
 1200 x 2400mm

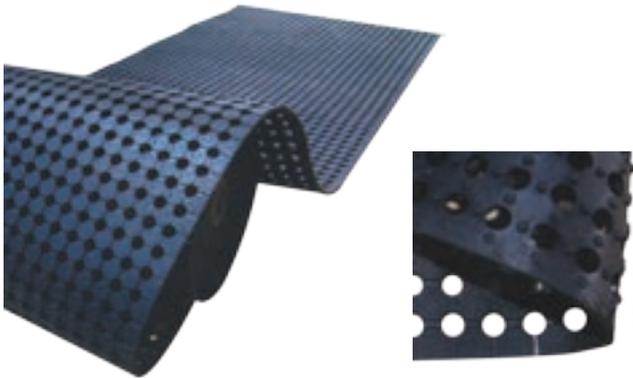

ANTI-FATIGUE ROLL MAT 690 - Roll Form Mat UTE MATTING

Versatile and can be easily cut to suit odd area.
 Provides very good comfort under foot.
 Raised pattern underneath to provide good drainage.
 Ideal for bars and food preparation areas.
 Ideal for boats, utes, vans, etc.
 Colour: Black

Sizes:
 900mm x 10.0m
 1800mm x 10.0m
 900mm runner
 1800mm runner

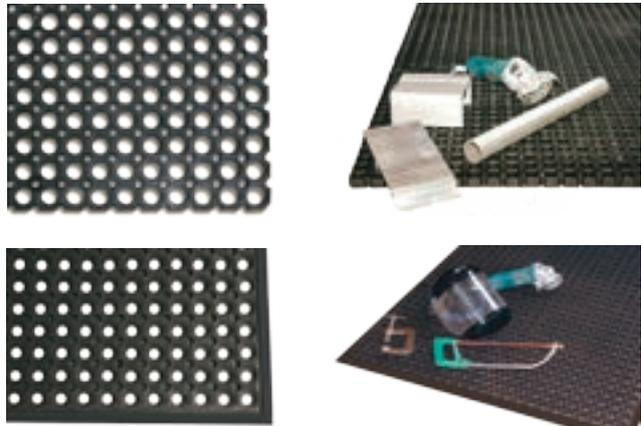

ENGINEERING MATS - Extreme Heavy Duty Mat

Drainage holes for water & debris
 Rugged Construction
 Ideal in front of machinery and welding bays
 Ideal for kitchens or workshops
 Available with or without bevelled edges for safety

Sizes:
 1000 x 1500mm
 1000mm runners
 Thickness 20mm

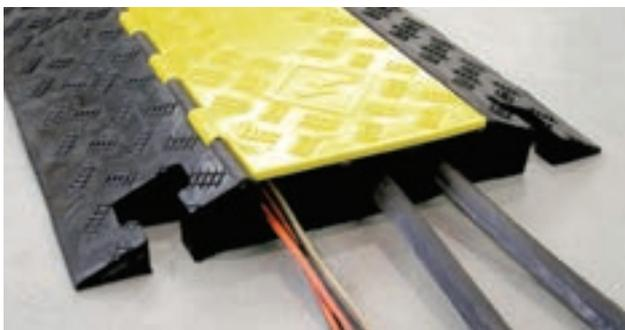

Rubber Cable Protector - 3 & 5 Channel

Rubber Body with Rubber/Plastic Lid.
 No Tool installation, Interlocking Modules.

Model	Description	Weight
CP3BODY 3 Channel	Body Size - 900 x 500 x 50mm 3 Channels Size - 55mm wide x 50mm deep	18kg
CP5BODY 5 Channel	Body Size - 900 x 500 x 70mm 5 Channels Size - 35mm wide x 25mm deep	15kg



Drop-Over Cable Protector - Single Channel

Moulded Polyethylene.
 No Tool installation, Interlocking Modules.

Model	Description	Weight
CP1BODY 1 Channel	Body Size - 1010 x 135 x 20mm 3 Channels Size - 40mm wide x 12mm deep	1.3kg



**SCF100B
Safety Cabinet
100L Class 3 Flammable Liquids**

Two Sequential Self Closing Doors.
Ventilation Ports with Flash Arrestors on each side.
Double Wall Thermal Barrier with 40mm Spacing.
Integral Spill Containment Sump with Drain and Suspended Perforated Floor.
Complies with AS1940-2004.

Model	Dimensions	Capacity
SCF100B	1100 x 510 x 860mm	100L



**SCF160B
Safety Cabinet
160L Class 3 Flammable Liquids**

Two Sequential Self Closing Doors.
Ventilation Ports with Flash Arrestors on each side.
Double Wall Thermal Barrier with 40mm Spacing.
Integral Spill Containment Sump with Drain and Suspended Perforated Floor.
Complies with AS1940-2004.

Model	Dimensions	Capacity
SCF160B	1100 x 510 x 1360mm	160L



**SCF250B
Safety Cabinet
250L Class 3 Flammable Liquids**

Two Sequential Self Closing Doors.
Ventilation Ports with Flash Arrestors on each side.
Double Wall Thermal Barrier with 40mm Spacing.
Integral Spill Containment Sump with Drain and Suspended Perforated Floor.

Model	Dimensions	Capacity
SCF250B	1100 x 510 x 1910mm	250L

All Measurements are Length x Width x Height



**GBC2S2HFG
Gas Bottle Cage - Two Tier**

Stores 4 x 18kg LPG Forklift Cylinders.
Aluminium Construction.
Padlockable Door (Lock not supplied).
Sloping Roof allows rainwater run off.
Complies with AS4332-2004.
Australian Made.

Model	Dimensions	Capacity
GBC2S2HFCG	800 x 450 x 1850mm	4 x 18kg LPG Cylinders



**GBC4S2HFG
Gas Bottle Cage - Two Tier**

Stores 8 x 18kg LPG Forklift Cylinders.
Aluminium Construction.
Mid Level Shelf.
Padlockable Door (Lock not supplied).
Sloping Roof allows rainwater run off.
Complies with AS4332-2004.
Australian Made.

Model	Dimensions	Capacity
GBC4S2HFG	800 x 800 x 1850mm	8 x 18kg LPG Cylinders



**GBC8LFG
Gas Bottle Cage**

Stores 8 x High Pressure Gas Cylinders.
Aluminium Construction.
Padlockable Door (Lock not supplied).
Sloping Roof allows rainwater run off.
Complies with AS4332-2004.
Australian Made.

Model	Dimensions	Capacity
GBC8LFG	868 x 831 x 1863mm	8 x HP Gas Cylinders



**SCC100B
Safety Cabinet
100L Class 8 Corrosive Substances**

Stores Class 8 Corrosive Substances.
Two Sequential Self Closing Doors.
Ventilation Ports with Flash Arrestors on each side.
Double Wall Thermal Barrier with 40mm Spacing.
Integral Spill Containment Sump with Drain and Suspended Perforated Floor.
Complies with AS3780-2008.

Model	Dimensions	Capacity
SCC100B	1100 x 510 x 860mm	100L

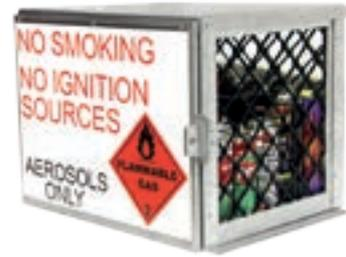

**ASC35
Aerosol Storage Cage**

Safety Storage Cage for 35 Aerosol Cans. (65mm diameter each).
Aluminium Construction.
Australian Made.
High Open Area Mesh provides natural ventilation.
Lockable Door with Padlock Lugs. (Padlock not supplied).
Complies with AS/NZS3833-2007.

Model	Dimensions	Capacity
ASC35	500 x 395 x 405mm	35 Aerosol Cans



**SCC160B
Safety Cabinet
160L Class 8 Corrosive Substances**

Stores Class 8 Corrosive Substances.
Two Sequential Self Closing Doors.
Ventilation Ports with Flash Arrestors on each side.
Double Wall Thermal Barrier with 40mm Spacing.
Integral Spill Containment Sump with Drain and Suspended Perforated Floor.
Complies with AS3780-2008.

Model	Dimensions	Capacity
SCC160B	1100 x 510 x 1360mm	160L



**ASC216
Aerosol Storage Cage**

Safety Storage Cage for 216 Aerosol Cans. (65mm diameter each).
Aluminium Construction.
Australian Made.
High Open Area Mesh provides natural ventilation.
Lockable Door with Padlock Lugs. (Padlock not supplied).
Complies with AS/NZS3833-2007.

Model	Dimensions	Capacity
ASC216	815 x 1065 x 475	216 Aerosol Cans



**SCC250B
Safety Cabinet
250L Class 8 Corrosive Substances**

Stores Class 8 Corrosive Substances.
Two Sequential Self Closing Doors.
Ventilation Ports with Flash Arrestors on each side.
Double Wall Thermal Barrier with 40mm Spacing.
Integral Spill Containment Sump with Drain and Suspended Perforated Floor.
Complies with AS3780-2008.

Model	Dimensions	Capacity
SCC250B	1100 x 510 x 1910mm	250L



**ASC360
Aerosol Storage Cage**

Safety Storage Cage for 360 Aerosol Cans. (65mm diameter each).
Aluminium Construction.
Australian Made.
High Open Area Mesh provides natural ventilation.
Lockable Door with Padlock Lugs. (Padlock not supplied).
Complies with AS/NZS3833-2007.

Model	Dimensions	Capacity
ASC360	815 x 1735 x 475mm	360 Aerosol Cans

All Measurements are Length x Width x Height

MANDATORY SIGNS



10M-MM
300 x 450mm Metal



14M-LP
225 x 300mm Poly
14M-MM
300 x 450mm Metal



40M-LP
225 x 300mm Poly

MANDATORY SIGNS



74M-IM
225 x 300mm Metal



130M-LP
225 x 300mm Poly
130M-MM
300 x 450mm Metal



S20-NM
600 x 450mm Metal
Multi Sign

PROHIBITION SIGNS



16P-LM
225 x 300mm Metal
16P-LP
225 x 300mm Poly



17P-LM
225 x 300mm Metal



401-MM
300 x 225mm Metal

DANGER SIGNS



93D-NP
600 x 450mm Poly
93D-NF
600 x 450mm Flute
93D-NP
600 x 450mm Metal



150D-NM
600 x 450mm Metal
150D-NF
600 x 450mm Flute



218S-M
300 x 450mm Metal

WARNING/CAUTION SIGNS



26W-LM
225 x 300mm Metal



48W-FA
150 x 225mm Adh
48W-LM
225 x 300mm Metal
48W-LP
225 x 300mm Poly



303L-SM
300 x 450mm Metal

EMERGENCY SIGNS



20E-LP
225 x 300mm Poly
20E-MP
300 x 450mm Poly



88E-LM
300 x 225mm Metal
88E-NM
600 x 450mm Metal
88E-NP
600 x 450mm Poly
88E-NF
600 x 450mm Flute



520L-SM
300 x 450mm Metal



Lockout/Tagout

Model	Description
UDT101	90 x 140mm, Packs of 100 - Card



Lockout/Tagout

Model	Description
UDT102	90 x 140mm, Packs of 100 - Card



Lockout/Tagout

Model	Description
UDT203	90 x 140mm, Packs of 100 - Card

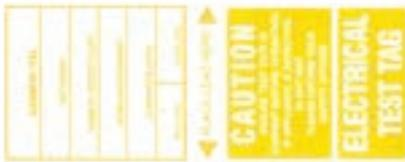

Test Tags

Model	Description
ETGYLW	Yellow Electrical Test Tag
ETGBLK	Black Electrical Test Tag
ETGRED	Red Electrical Test Tag
ETGGRN	Green Electrical Test Tag
ETGOGE	Orange Electrical Test Tag
ETGWHI	White Electrical Test Tag

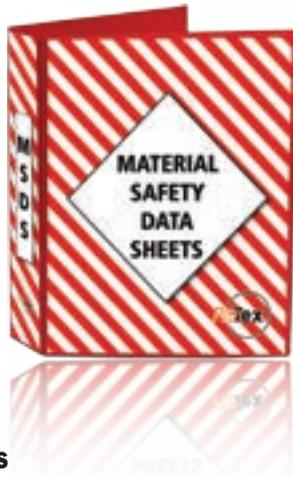

MSDS

Model	Description
MSDSB	A4 Binder - Red/White



Padlocks

Model	Description
UL418	42mm Premium Red Safety Padlock
UL419	42mm Premium Red Safety Padlock (3 Pack)
UL400	42mm Premium Blue Safety Padlock
UL401	42mm Premium Orange Safety Padlock
UL402	42mm Premium Yellow Safety Padlock
UL403	42mm Premium Green Safety Padlock
UL404	42mm Premium Black Safety Padlock
UL406	75mm Premium Red Safety Padlock
UL407	75mm Premium Blue Safety Padlock
UL408	75mm Premium Orange Safety Padlock
UL409	75mm Premium Yellow Safety Padlock
UL413	75mm Premium Green Safety Padlock
UL414	75mm Premium Black Safety Padlock



Padlocks

Model	Description
UL415	42mm Premium Red Padlock (3 Pack) with Master Key
UL416	42mm Premium Red Padlock (4 Pack) with Master Key
UL417	42mm Premium Red Padlock (5 Pack) with Master Key



Starter Kit

A great starter kit with all the necessary components to satisfy most applications.

Model	Description
UL321	Complete Starter Kit



Lockout Stations

Model	Description
UL304	410 x 410 x 75mm



ACS1
Anti Collision Strip - V

Impact Protection Foam Buffer.

Features	Specifications
Material	Soft Polyurethane Foam
Finish	Black/Yellow Diagonal Stripes
Profile	'V' Shape
Dimensions	1000 x 40 x 20mm
Weight	0.4kg per metre
Installation	Peel & Stick



ACS2
Anti Collision Strip - Rectangular

Impact Protection Foam Buffer.

Features	Specifications
Material	Soft Polyurethane Foam
Finish	Black/Yellow Diagonal Stripes
Profile	'Rectangular' Shape
Dimensions	1000 x 60 x 20mm
Weight	0.4kg per metre
Installation	Peel & Stick



ACS3
Anti Collision Strip - L

Impact Protection Foam Buffer.

Features	Specifications
Material	Soft Polyurethane Foam
Finish	Black/Yellow Diagonal Stripes
Profile	'L' Shape
Dimensions	1020 x 60 x 40mm
Weight	0.4kg per metre
Installation	Peel & Stick



ACS4
Anti Collision Strip - C

Impact Protection Foam Buffer.

Features	Specifications
Material	Soft Polyurethane Foam
Finish	Black/Yellow Diagonal Stripes
Profile	'C' Shape
Dimensions	1010 x 40 x 6mm
Weight	0.4kg per metre
Installation	Peel & Stick

LADDERS & ACCESS EQUIPMENT



Work Platforms.....	96
TeamSteps.....	97
Monstar Steps & Ladders	98-101
Platform Ladders.....	102-104
Double Sided & Extension Ladders	105
Mobile Platforms	106-107
Mezzanine Access & Lifts	108

These Team Systems Work Platforms are the only safe and authority approved way of lifting personnel to a height when using a forklift.

TSWP - Work Platform

Manufactured to meet Australian Standards - AS-2359.1.
 Designed to carry 2 people & up to 250kg.
 1200 x 1200 x 1000mm with 2200mm Safety Screen.
 Toe Boards on all sides.
 Skid Resistant Floor Plates.
 Inward Opening Self Closing Door.
 Internal Hand Rail.
 Full Length Fork Sleeves.
 Safety Chains Fitted.
 40mm Square Tube Construction.
 Pins supplied for attaching to fork.
 Two Harness Anchor Points.
 Precision made Quality Construction.
 Australian Made.

APPROVED PERSONNEL PLATFORM!



BH01151 Safety Harness (optional)

Energy Absorbing 2.0m Lanyard.
 Particularly suited to the hire industry.
 Fall/Arrest 136kg.
 Only available for use on fully welded work platform as per the TSWP pictured here.
 NOTE: The use of a safety harness is not mandatory with this platform.



TSWPF Collapsible, Folding Work Platform

250kg Rating
 Stores & assembles with ease.
 Ideal for freighting.
 Complies with Australian Safety Standards - AS-2359-1.
 Comes ready to use.



FOLDS AWAY IN ONLY 5 MINUTES!





visit www.teamstep.com.au
for the latest information & details
on all our TeamStep products.

TEAMSTEP

STEP UP® "Strongest & Safest Unit in the Market"

Large Deck Size 370mm x 370mm.
Fitted with Non-Slip Tape.
Four Way Access.
Standard with Rubber Feet

Available in Orange & Yellow.

• SCHOOLS • OFFICE • WAREHOUSE & RETAIL

Model	Size	Height	Capacity	Weight
TSSU	370 x 370mm	370mm	180kg	5.0kg

ORANGE

YELLOW



TEAM STEP

TEAMSTEP

MOBILE TEAMSTEP® "Always a Step Above"

Totally Mobile.
Anti-Slip Surface.
Lightweight, Durable One Piece Construction.
Stackable.
No rusting or dangerous sharp edges.
Castors are springloaded to retract
when TEAMSTEP is in use.
Fitted with Non-Slip Tape.
Made of Rotomoulded Plastic.

Available in Blue & Yellow

• SCHOOLS • OFFICE • WAREHOUSE & RETAIL

Model	Size	Height	Capacity	Weight
TSTS	315mm	395mm	180kg	4.2kg

BLUE

YELLOW



TEAMSTEP

JUMBO TEAMSTEP® "Best of Both Worlds"

All the benefits of the TEAMSTEP® but with the large deck size
of the Square STEP-UP®

Totally Mobile.
Anti-Slip Surface.
Lightweight, Durable One Piece Construction
Stackable.
Castors are springloaded to retract
when TEAMSTEP is in use.
Fitted with Non-Slip Tape.

Available in Yellow.

• OFFICE • WAREHOUSE • SHOP • SCHOOLS
• IDEAL FOR TRADESPEOPLE

Model	Size	Height	Capacity	Weight
TSJUMBO	375mm	355mm	180kg	4.2kg

YELLOW



LADDERS & ACCESS EQUIPMENT

MONSTAR STEP

www.monstarladders.com.au



MONSTAR STEP

Outperforms other similar safety steps in longevity and strength.

The all new Monstar Step is the only plastic safety step that has superior design features over existing injection moulded safety steps available in Australia. The Monstar Step is a quality, cost effective solution designed for intermittent use. Designed to be durable, safe and robust.

Monstar Step has a larger, safer area of non slip tape including an indentation on the lower step so the tape will not wear away - ensuring longevity of non slip surface.

The Monstar Steps come with the following features, benefits and specifications.

- **LARGE DECK SIZE**
- **180KG RATED**
- **LIGHTWEIGHT**

- Large Deck Size - 370mm x 370mm.
- Fully Fitted with Non-Slip Tape.
- Four Way Access.
- Rubber Feet.



MONSTAR STEP

Model	Deck Size	Height	Capacity	Weight
MONSTEP	370 x 370mm	375mm	180kg	3.5kg



LADDERS & ACCESS EQUIPMENT

LITTLE MONSTAR

www.monstarladders.com.au



Compact Step Ladder designed for safe, easy and efficient use for a wide range of applications.

A range of Compact Step Ladders designed and manufactured to meet the highest demanding applications in Australia.

These ladders are built with industry rated material for moderate to high level use.

- Made to Australian and New Zealand Standards AS/NZS 1892.1.
- 150kg Load Rating.
- Lightweight, Manoeuvrable and easy to use.
- Rear Roller Castors for ease of movement.
- Heavy Duty Tread for added safety on all steps.
- Strong Safety Bracket including recess for Storing Tools and Bucket Hooks
- Light, Strong, Aluminium Construction.



- ALUMINIUM
- 150KG HEAVY-DUTY
- LIGHTWEIGHT

150kg Compact Step Ladder

Model	Type	Footprint	Top Step Height	Safety Bracket Height	Dimensions	Weight
MONLM2	2 Step	620 x 530mm	480mm	480mm	900 x 550 x 150mm	6kg
MONLM3	3 Step	900 x 550mm	680mm	480mm	1200 x 580 x 150mm	8kg
MONLM4	4 Step	1180 x 550mm	910mm	760mm	1500 x 580 x 150mm	9kg
MONLM5	5 Step	1440 x 585mm	1130mm	760mm	1800 x 600 x 150mm	11kg

MONSTAR LADDER

www.monstarladders.com.au



MONSTAR ORDER PICKERS

Designed for easy, efficient use in warehousing and workplace environments.

Monstar Order Picking Ladders provide safe and secure access to all your elevated stock.

All Monstar Order Picking Ladders feature a huge 585mm x 730mm work platform, retractable safety castors and a 150kg Rated Capacity, reinforced with a strong welded construction.

The Monstar Order Picker is guaranteed to make stock picking safer and more efficient for your business.

- ALUMINIUM
- 150KG HEAVY-DUTY
- LIGHTWEIGHT

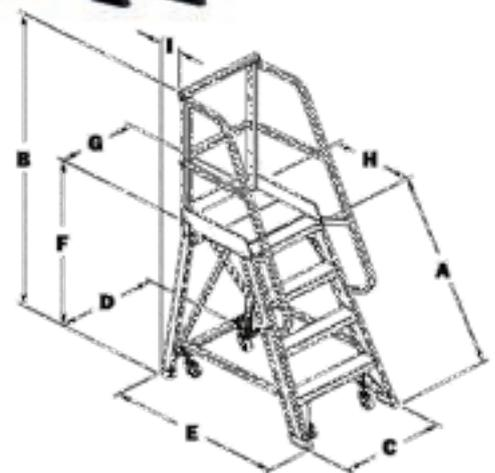

- Made to AS/NZS 1892.1.
- Spring Loaded Castors.
- Safety Gate for Security and Stability at Elevated Heights.
- Designed for use on Commercial Sites and Warehouses.
- Light, Strong, Aluminium Construction with Ribbed Tread.
- Fully Welded Construction.
- Lightweight, Manoeuvrable & easy to use.

150kg Order Picker

Model	Type	A	B	Footprint C x E	D	F	G	H	I
MONOP2	2 Step	620mm	1466mm	675 x 1025mm	659mm	565mm	585mm	730mm	17mm
MONOP3	3 Step	927mm	1742mm	715 x 1167mm	695mm	840mm	585mm	730mm	37mm
MONOP4	4 Step	1222mm	2017mm	758 x 1305mm	735mm	1115mm	585mm	730mm	60mm
MONOP5	5 Step	1524mm	2290mm	800 x 1460mm	775mm	1390mm	585mm	730mm	87mm
MONOP6	6 Step	1812mm	2570mm	844 x 1595mm	815mm	1665mm	585mm	730mm	112mm

LADDERS & ACCESS EQUIPMENT

MONSTAR LADDER

www.monstarladders.com.au



Strong, Lightweight Platform Ladder designed for Heavy Duty Industrial use.

A range of Platform Ladders designed and manufactured to meet the highest demanding applications in Australia.

These ladders are built with industry rated material for moderate to high level use.

- Fully Welded Construction.
- Checkerplate Platform.
- Wide Base with Rubber Feet.
- 700mm x 400mm Platform
- Exceeds AS/NZS 1892.1.
- Standard Work Platform.
- Fully Welded Retractable Castors.
- Optional Handrails Available.



SAFETY BAR



LARGE PLATFORM



CASTOR WHEELS



MONSTAR3



MONSTAR5



- ALUMINIUM
- 150KG HEAVY-DUTY
- LIGHTWEIGHT

150kg Platform Ladder

Model	Platform Height	Steps
MONSTAR2	570mm	2
MONSTAR3	850mm	3
MONSTAR4	1130mm	4
MONSTAR5	1410mm	5
MONSTAR6	1690mm	6

HR - OPTIONAL HAND RAIL



SAFETY GATE



FOLDED LADDER



INDALEX INDUSTRIAL ALUMINIUM SLIMLINE PLATFORM LADDER 120KG

Special Slim ladder, lightweight, easy to store.
 Strong construction with aluminium hinge & connection between steps.
 TRDP5/2 - TRDP7/4 Fold to just 40mm thick.
 Impressive 150kg load rating on TRDP8/5.
 Industrial Duty Rated. Designed for use on industrial work sites.
 Light, Strong, Aluminium Construction.
 Double Sided for greater versatility and greater load bearing strength.
 Anti-slip Feet for added safety & stability.
 Made to Australian & New Zealand Standards AS/NZS 1892.1:1996.
 1 Year Warranty.

TRDP5/2 & TRDP7/4
FOLD TO JUST 40mm THICK!



TRD6/3

Model	Overall Height	Platform Height	Weight
TRDP5/2	1520mm	600mm	5.6kg
TRDP6/3	1830mm	900mm	6.9kg
TRDP7/4	2130mm	1200mm	8.3kg
TRDP8/5	2130mm	1500mm	11kg

INDALEX ALUMINIUM PLATFORM 150KG

Industrial Duty Rated.
 Heavy Duty 150kg Load Rating.
 Large Extruded Anti-slip Work Platform.
 Anti Slip Rubber Feet for added safety and stability.
 Made to Australian Standards - AS/NZS 1892.1.
 Platform Work Area - 660mm x 400mm.
 Solid 900mm High Guard Rail.
Also Available - Wheel Kits, Locking Gates, Hand Rails, Tool Tray and Heavy Duty Top Shelf



PROPG - Locking Gate & Tray

PROP7/4

Model	Platform Height	Weight
PROP5/2	600mm	11.0kg
PROP6/3	900mm	12.0kg
PROP7/4	1200mm	13.0kg
PROP8/5	1500mm	14.0kg
PROP9/6	1800mm	16.0kg
PROP10/7	2100mm	20.0kg
PROP11/8	2400mm	22.0kg
PROP12/9	2700mm	24.0kg
PROP13/10	3000mm	26.0kg
PROP15/12	3600mm	30.0kg

P170 JOB STATION 170KG ALUMINIUM PLATFORM STEP LADDER

Huge Platform Area (610 x 457mm).
 Extra Strong, Heavy Duty Aluminium Construction.
 New 'Trapezoidal Tread Design' provides an incredibly strong tread to stile joint.
 Multi-function Handrail with optional 'DropLok' Accessories.
 Fully Integrated Bracing and Castor System.
 Made to AS/NZ 1892.1.



FS13538

Model	Platform Height	Maximum Reach	Weight
FS13538	900mm	2870mm	16.90kg
FS13538	1200mm	3160mm	18.40kg
FS13538	1500mm	3450mm	19.90kg
FS13538	1800mm	3740mm	21.90kg
FS13538	2030mm	4030mm	27.40kg
FS13538	2320mm	4320mm	28.40kg
FS13538	2910mm	4910mm	33.20kg
FS13538	3490mm	5490mm	37.60kg

PROFESSIONAL PLATFORM WITH GATE OPTION 170KG

Industrial Duty Rated. Designed for use on industrial work sites.
 Made to Australian & New Zealand Standards AS/NZS 1892.1.
 'Fold Away' Safety Gate Standard on 7-12 Step Model.

Available - **Optional Retractable Castors/Wheels Kits.**

Optional 'Fold Away' Safety Gate for 2-6 Step Model.



Model	Optional Gate	Platform Height	Weight
FS13398	-	575mm	8.1kg
FS13399	-	860mm	8.9kg
FS13400	-	1146mm	10.4kg
FS13401	-	1431mm	12.1kg
FS13402	-	1716mm	13.0kg
FS13455	Included	2100mm	20.8kg
FS13456	Included	2400mm	22.9kg
FS13457	Included	2850mm	34kg
FS13458	Included	3420mm	38kg
FS22971 Castor/Wheel Kit	-	Fits 2-6' Platform	2.54kg
FS22972 Castor/Wheel Kit	-	Fits 7-8' Platform	2.54kg
FS13324 Safety Gate	-	-	2.5kg



Gate Option - Closed



Gate Option - Open



FS13400

PLATFORM LADDERS



INDALEX PRO SERIES INDUSTRIAL FIBREGLASS PLATFORM LADDER 150KG

Platform Work Area - 660mm x 400mm.
 Solid 900mm High Guard Rail.

Available - **Wheel Kits, Locking Gates, Hand Rails, Tool Tray and Heavy Duty Top Shelf**



PROPFWK - Castor/Wheel Kit

Model	Platform Height	Weight
PROPF5/2	600mm	13.0kg
PROPF6/3	900mm	14.0kg
PROPF7/4	1200mm	16.0kg
PROPF8/5	1500mm	17.0kg
PROPF9/6	1800mm	20.0kg
PROPF10/7	2100mm	24.0kg
PROPF11/8	2400mm	26.0kg
PROPF12/9	2700mm	28.0kg
PROPF13/10	3000mm	30.0kg
PROPF15/12	3600mm	36.0kg



PROPF74



INDALEX ALUMINIUM DUAL PURPOSE LADDER 150KG

Pro Series Lifetime Warranty.
 Double solid Aluminium Rivet Constructions to withstand repeated use without the joints loosening.

Model	Ladder Size	Weight
PRODP6	1.8/3.2m	8.8kg
PRODP7	2.1/3.8m	10.0kg
PRODP8	2.4/4.4m	12.0kg



PRODP6

LADDERS & ACCESS EQUIPMENT

StockMaster Surefoot

Transportable Platform Ladder.
 Large Reinforced Aluminium Platform.
 Full Box Section Steps for maximum strength.
 Full Boot Anti-Slip Feet.
 Double Locked Frame for increased rigidity.
 150kg Rating.

Model	Platform Height	Maximum Reach	Weight
SMSF04	1100mm	2900mm	13.95kg
SMSF05	1250mm	3150mm	16.15kg
SMSF06	1500mm	3400mm	17.75kg
SMSF07	1750mm	3650mm	19.70kg
SMSF08	2000mm	3900mm	21.40kg



DEEP STEP TREAD



SUPERIOR FRAME STRENGTH



FULL BOOT FOOT



SMSF05

StockMaster Omni

Transportable, Mobile Platform Ladder.
 All Terrain - Indoor and Outdoor use.
 Single Control for Braking and Steering.
 150kg Load Rating.
 Moves on Wheels in open and closed position. *Carry your tools and not the ladder.*

Model	Platform Height	Maximum Reach	Weight
SMOSF04	1100mm	2900mm	18.95kg
SMOSF05	1250mm	3150mm	21.15kg
SMOSF06	1500mm	3400mm	22.75kg
SMOSF07	1750mm	3650mm	24.70kg
SMOSF08	2000mm	3900mm	26.40kg



DEEP STEP TREAD



SUPERIOR FRAME STRENGTH



FULL BOOT FOOT



SMOSF05

StockMaster OmniPro

Transportable, Mobile Platform Ladder.
 All Terrain - Indoor and Outdoor use.
 Single Control for Braking and Steering.
 150kg Load Rating.
 Moves on Wheels in open and closed position. *Carry your tools and not the ladder.*

Additional Features:
 Smart Action Safety Gate at platform entry.
 Waist Height Tool Tray.
 Safety Gate and Tool Tray fold for transport.

Model	Platform Height	Maximum Reach	Weight
SMPSF04	1100mm	2900mm	22.05kg
SMPSF05	1250mm	3150mm	24.25kg
SMPSF06	1500mm	3400mm	25.85kg
SMPSF07	1750mm	3650mm	27.80kg
SMPSF08	2000mm	3900mm	29.50kg



SMPSF05





**INDALEX ALUMINIUM
DOUBLE SIDED STEP LADDER
120KG 135KG 150KG 180KG**

3 Year Warranty for Tradesman and Lifetime warranty for Pro Series.
Double solid Aluminium Rivet Constructions to withstand repeated use without the joints loosening.

Model	Ladder Size	Weight
TRDS2D - 150kg	600mm	3.0kg
TRDS3D - 150kg	900mm	4.1kg
TRDS4D - 150kg	1200mm	4.9kg
TRDS5D - 135kg	1500mm	6.5kg
TRDS6D - 135kg	1800mm	7.4kg
TRDS7D - 120kg	2100mm	9.2kg
TRDS8D - 120kg	2400mm	10.0kg
PROS9D - 180kg	2700mm	14.0kg
PROS10D - 180kg	3000mm	16.0kg
PROS12D - 150kg	3600mm	20.0kg
PROS14D - 150kg	4300mm	25.0kg
PROS16D - 150kg	4800mm	30.0kg



INDALEX FIBREGLASS DOUBLE SIDED 150KG & 180KG

Double Solid Aluminium Rivet Construction to withstand repeated use without the joints loosening.
Robust Fibreglass Side Rails utilising UV Inhibitors for greater durability.
5 Year Warranty.
Heavy Duty Fixed Feet for 8ft - 16ft.

Model	Ladder Size	Weight
PROSF3D - 180kg	900mm (3')	5.8kg
PROSF4D - 180kg	1200mm (4')	7.4kg
PROSF5D - 180kg	1500mm (5')	9.2kg
PROSF6D - 180kg	1800mm (6')	11.0kg
PROSF7D - 180kg	2100mm (7')	13.0kg
PROSF8D - 180kg	2400mm (8')	15.0kg
PROSF10D - 180kg	3000mm (10')	21.0g
PROSF12D - 150kg	3700mm (12')	26.0kg
PROSF14D - 150kg	4300mm (14')	30.0kg
PROSF16D - 150kg	4800mm (16')	36.0kg



**INDALEX INDUSTRIAL ALUMINIUM
EXTENSION LADDER 135KG**

3 Year Warranty.
Industrial Duty Rated. Designed for use on industrial work sites.
Light, Strong, Aluminium Construction.
Double Sided for greater versatility and greater load bearing strength.
Anti-slip Feet for added safety & stability.
Made to Australian & New Zealand Standards AS/NZS 1892.1.

Model	Ladder Size	Weight
TRDX16	2.9/4.7m	12.5kg
TRDX18	3.2/5.3m	13.5kg
TRDX22	3.8/6.6m	15.5kg





**INDALEX INDUSTRIAL
FIBREGLASS EXTENSION LADDER 120KG & 135KG**

3 Year Warranty.

Made to Australian & New Zealand Standards AS/NZS 1892.1.

V-Bracket fitted as standard.

Available - **Optional Retractable Castors/Wheels Kits.**

Optional 'Fold Away' Safety Gate for 2-6 Step Model.

Model	Ladder Size	Weight
TRDXF14 (135kg)	2.8/4.3m	17kg
TRDXF18 (135kg)	3.4/5.5m	21kg
TRDXF22 (135kg)	4.0/6.7m	24kg
TRDXF26 (120kg)	4.9/8.2m	30kg



TRDXF22



**TEAM SYSTEMS
MOBILE ORDER PICKING LADDERS 150KG**

Australian Made.

Platform locks securely in place when the first step is lowered and becomes mobile once more when step is raised.

Supplied Flat Packed - Assembly Required.

Model	Platform Height	Weight
TSL2	480mm	60kg
TSL3	715mm	63kg
TSL4	950mm	65kg
TSL5	1185mm	68kg
TSL6	1420mm	75kg
TSL7	1660mm	86kg
TSL8	1890mm	96kg
TSL9 OR	2140mm	116kg
TSL10 OR	2310mm	135kg
TSL11 OR	2570mm	152kg
TSL12 OR	2810mm	166kg

**ZINC PLATED
ALL STEEL
CONSTRUCTION**

Supplied Flat Packed -
Assembly is available on request.



TSL5

OR - INCLUDES OUT RIGGERS



**ACCESS PLATFORM
ALUMINIUM 170KG**

Super Strong, Fully Welded Design fabricated from Heavy Duty Aluminium.

'Walk Thru' Design for stock picking and access to mezzanine floors.

Large 125mm Wheels.

Two Safety Gates fitted (2 in 1 product allowing for walk-thru access).

Made to AS/NZS 1892.1.

Supplied Flat Packed - Assembly Required.

Model	Platform Height	Weight
FS13591	828mm	38.1kg
FS13592	1104mm	40.6kg
FS13593	1381mm	43.0kg
FS13594	1656mm	46.0kg
FS13595	1933mm	48.5kg
FS13596	2209mm	40.5kg
FS13597	2761mm	51.0kg
FS13598	3313mm	69.0kg
FS13599	3866mm	76.4kg

**'WALK THROUGH'
MODEL**

Supplied Flat Packed -
Assembly is available on request.



FS13591

StockMaster Navigator

Automatic Braking.
Fast Repositioning
Highly Manoeuvrable.

ADDITIONAL FEATURES:
Automatic Safety Gate at Platform Entry.
Side Opening Rota-Gate for easy stock picking.



Model	Height	5kg Working Range	20kg Working Range
SMN04	1145mm	1.4 - 2.8m	1.4 - 2.3m
SMN05	1435mm	1.7 - 3.1m	1.7 - 2.6m
SMN06	1720mm	2.0 - 3.4m	not suitable
SMN07	2005mm	2.3 - 3.7m	not suitable
SMN08	2295mm	2.5 - 3.9m	not suitable
SMN09	2580mm	2.8 - 4.2m	not suitable
SMN10	2865mm	3.1 - 4.5m	not suitable
SMN11	3155mm	3.4 - 4.8m	not suitable
SMN12	3440mm	3.7 - 5.1m	not suitable
SMN13	3735mm	4.0 - 5.4m	not suitable
SMN14	4015mm	4.3 - 5.7m	not suitable



SMN5



StockMaster LiftTruk

Lifts up to 60kg.
No Battery Required.
Greatly Improves Safety.

Also Available in PRO Version with Safety Gate and Rota Gate.



Model	Height	5kg Working Range	20kg Working Range
SMLT04M	1145mm	1.4 - 2.8m	1.4 - 2.3m
SMLT05M	1435mm	1.7 - 3.1m	1.7 - 2.6m
SMLT06M	1720mm	2.0 - 3.4m	2.0 - 2.9m
SMLT07M	2005mm	2.3 - 3.7m	2.3 - 3.2m
SMLT08M	2295mm	2.5 - 3.9m	2.5 - 3.4m
SMLT09M	2580mm	2.8 - 4.2m	2.8 - 3.7m
SMLT010M	2865mm	3.1 - 4.5m	3.1 - 4.0m
SMLT011M	3155mm	3.4 - 4.8m	3.4 - 4.2m
SMLT012M	3440mm	3.7 - 5.1m	3.7 - 4.6m
SMLT013M	3735mm	4.0 - 5.4m	4.0 - 4.9m
SMLT014M	4015mm	4.3 - 5.7m	4.3 - 5.2m



SMLT04M



StockMaster Tracker

Lifts up to 60kg.
No Battery Required.
Greatly Improves Safety.

Also Available in PRO Version with Safety Gate and Rota Gate.



Model	Height	Working Range
SMT03	860mm	1.1 - 2.7m
SMT04	1145mm	1.4 - 3.0m
SMT05	1435mm	1.7 - 3.3m
SMT06	1720mm	2.0 - 3.6m
SMT07	2005mm	2.3 - 3.9m
SMT08	2295mm	2.9 - 4.2m
SMT09	2580mm	2.8 - 4.4m
SMT10	2865mm	3.1 - 4.7m
SMT11	3155mm	3.4 - 5.0m
SMT12	3440mm	3.7 - 5.3m
SMT13	3735mm	4.0 - 5.6m
SMT14	4015mm	4.3 - 5.9m



SMT06



StockMaster StepThru



Mobile Access Steps for Indoor and Outdoor Use.
 Provides safe flexible access for Container Loading, Transport Vehicles, Loading Docks and Mezzanine Floors.
 Moves easily over sealed or unsealed surfaces and slopes.
 150kg Load Rating.

Model	Platform Height	Service Height Rating
SMST03	860mm	2529mm
SMST04	1145mm	2744mm
SMST05	1435mm	2977mm
SMST06	1720mm	
SMST07	2005mm	
SMST08	2295mm	
SMST09	2580mm	
SMST10	2865mm	3225mm



SMST04



StockMaster Mezzalad



Personnel Access Ladder for access to Mezzanines, Lofts and other Elevated Work and Storage areas.
 Stores flat against the wall and is brought to the use position with a simple lift and pull action.
 Includes a Safety Gate at the upper floor level.

Model	Minimum Service Height	Maximum Service Height
SMVH01	2330mm	2529mm
SMVH02	2529mm	2744mm
SMVH03	2744mm	2977mm
SMVH04	2977mm	3225mm



SMVH03

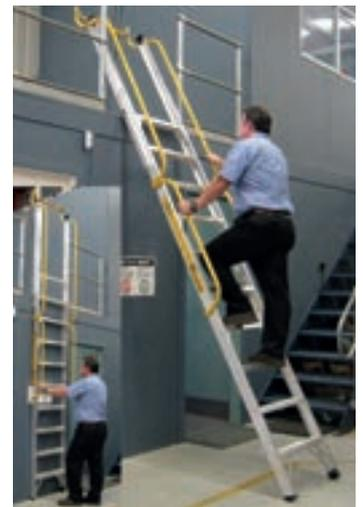

StockMaster Mezzalift



Manually operated Goods Lift for transfer of single items or stacked loads to Mezzanine floors and other Elevated Work and Storage areas.
 Maximum recommended load 60kg.
 Adjusts in length to suit the height of the mezzanine.

Model	Service Height Rating
SMMH01	2248 - 2553mm
SMMH02	2535 - 2840mm
SMMH03	2822 - 3127mm
SMMH04	3109 - 3414mm
SMMH05	3396 - 3701mm
SMMH06	3683 - 3988mm
SMMH07	3970 - 4275mm



SMMH02



PLASTICS & SHELVING



Stack & Nest Containers.....	110-114
Ventilated Crates, Buckets & Bins.....	115-116
Bulk Bins & Pallets	117
Storage Containers	118-119
Rotationally Moulded Bins & Tanks	120-121
Wheelie Bins, Work Benches & Storage.....	122-123
Longspan Shelving & Lockers	124-125



YELLOW
GREEN
GREY
RED
BLUE
NATURAL

IH060 - Stack & Nest
IH052 - Lid

Capacity	External Dimensions	Internal Dimensions
32 Litre	645 x 413 x 210mm	597 x 362 x 203mm



YELLOW
GREEN
GREY
RED
BLUE
NATURAL

IH051 - Stack & Nest
IH052 - Lid

Capacity	External Dimensions	Internal Dimensions
52 Litre	645 x 413 x 276mm	597 x 362 x 266mm



YELLOW
GREEN
GREY
RED
BLUE
NATURAL

IH078 - Stack & Nest
IH052 - Lid

Capacity	External Dimensions	Internal Dimensions
68 Litre	645 x 413 x 397mm	597 x 362 x 381mm



YELLOW
GREEN
BLACK

IH060R2 - Stack & Nest
IH052R2 - Lid (Black only)
Moulded from recycled resin
Not recommended for food

Capacity	External Dimensions	Internal Dimensions
32 Litre	645 x 413 x 210mm	597 x 362 x 203mm



YELLOW
GREEN
BLACK

IH051R2 - Stack & Nest
IH052R2 - Lid (Black only)
Moulded from recycled resin
Not recommended for food

Capacity	External Dimensions	Internal Dimensions
52 Litre	645 x 413 x 276mm	597 x 362 x 266mm



YELLOW
GREEN
BLACK

IH078R2 - Stack & Nest
IH052R2 - Lid (Black only)
Moulded from recycled resin
Not recommended for food

Capacity	External Dimensions	Internal Dimensions
68 Litre	645 x 413 x 397mm	597 x 362 x 381mm



BLUE
NATURAL

IH2520 - Stack & Nest

Capacity	External Dimensions	Internal Dimensions
52 Litre	578 x 384 x 318mm	502 x 338 x 300mm



BLUE
NATURAL

IH2780 - Stack & Nest

Capacity	External Dimensions	Internal Dimensions
78 Litre	578 x 384 x 470mm	502 x 338 x 455mm



RED
GREEN
NATURAL

IH2260 - Stack & Nest

Capacity	External Dimensions	Internal Dimensions
26 Litre	578 x 384 x 166mm	502 x 338 x 150mm



NATURAL

IH090 - Stack & Nest

Capacity	External Dimensions	Internal Dimensions
32 Litre	575 x 400 x 215mm	510 x 355 x 178mm



NATURAL

IH068 - Stack & Nest

Capacity	External Dimensions	Internal Dimensions
118 Litre	950 x 460 x 435mm	770 x 365 x 365mm



NATURAL

IH066 - Stack & Nest

Capacity	External Dimensions	Internal Dimensions
54 Litre	711 x 438 x 283mm	673 x 400 x 276mm

All Measurements are Length x Width x Height
Lids to suit the containers are only available in Natural colour unless otherwise specified.



IH004 - Vented

BEIGE

Capacity	External Dimensions	Internal Dimensions
84 Litre	585 x 522 x 350mm	560 x 495 x 320mm



IH016 - Stack & Nest

NATURAL

Capacity	External Dimensions	Internal Dimensions
16 Litre	580 x 380 x 175mm	520 x 340 x 160mm



NOTE: NOT A STOCK ITEM
Minimum Quantity applies to this product.

IH033 - Stack & Nest

BLACK

Capacity	External Dimensions	Internal Dimensions
21 Litre	580 x 385 x 130mm	540 x 347 x 110mm



IH065 - Stack & Nest

NATURAL

Capacity	External Dimensions	Internal Dimensions
54 Litre	711 x 438 x 283mm	673 x 400 x 276mm



IH035 - Stack & Nest

NATURAL

Capacity	External Dimensions	Internal Dimensions
35 Litre	711 x 438 x 218mm	673 x 400 x 190mm



IH095 - Transporter

NATURAL

Capacity	External Dimensions	Internal Dimensions
32 Litre	642 x 480 x 156mm	584 x 432 x 127mm



IH317 - Stack & Nest

Vented Sides/Vented Base

IH318 - Stack & Nest

Vented Sides/Solid Base

YELLOW

Capacity	External Dimensions	Internal Dimensions
32 Litre	580 x 390 x 190mm	505 x 305 x 165mm



IH323 - Bread Crate

GREY

Capacity	External Dimensions	Internal Dimensions
48 Litre	691 x 604 x 152mm	662 x 578 x 126mm



IH506 - Produce Crate

ORANGE

Capacity	External Dimensions	Internal Dimensions
22 Litre	525 x 336 x 240mm	442 x 280 x 228mm



IH512 - Produce Crate

GREEN
ORANGE

Capacity	External Dimensions	Internal Dimensions
36 Litre	525 x 336 x 345mm	430 x 272 x 333mm



IH2267 - Stack & Nest

GREEN
NATURAL

Capacity	External Dimensions	Internal Dimensions
26 Litre	578 x 384 x 166mm	502 x 338 x 150mm



IH2527 - Stack & Nest

BLUE
NATURAL

Capacity	External Dimensions	Internal Dimensions
52 Litre	578 x 384 x 318mm	502 x 338 x 300mm

All Measurements are Length x Width x Height
Lids to suit the containers are only available in Natural colour unless otherwise specified.



IH007 - Confectionery Tray

NATURAL

Capacity	External Dimensions	Internal Dimensions
29 Litre	712 x 448 x 95mm	680 x 416 x 76mm



IH047 - Stacking Crate

BLACK
NATURAL

Capacity	External Dimensions	Internal Dimensions
21 Litre	660 x 334 x 121mm	610 x 305 x 114mm



IH072 - Stacking Crate

NATURAL

Capacity	External Dimensions	Internal Dimensions
36 Litre	565 x 387 x 203mm	553 x 355 x 190mm



IH024 - Auto Crate

GREY

Capacity	External Dimensions	Internal Dimensions
25 Litre	580 x 385 x 166mm	518 x 335 x 140mm



IH046 - Stacking Crate

NATURAL

Capacity	External Dimensions	Internal Dimensions
46 Litre	629 x 400 x 216mm	597 x 368 x 210mm



IH099 - Slab Side Crate

BLUE
GREEN

Capacity	External Dimensions	Internal Dimensions
29 Litre	356 x 356 x 292mm	331 x 331 x 279mm



IH305 - Small Tote Box
IH308 - Lid (White only)

BLUE
WHITE

Capacity	External Dimensions	Internal Dimensions
13 Litre	432 x 324 x 127mm	387 x 286 x 120mm



IH306 - Medium Tote Box
IH308 - Lid (White only)

BLUE
WHITE

Capacity	External Dimensions	Internal Dimensions
21 Litre	432 x 324 x 203mm	387 x 286 x 197mm



IH307 - Large Tote Box
IH308 - Lid

BLUE
WHITE

Capacity	External Dimensions	Internal Dimensions
33 Litre	432 x 324 x 305mm	387 x 286 x 298mm



IH220 - Large Tote Box
IH221 - Lid

NATURAL

Capacity	External Dimensions	Internal Dimensions
42 Litre	520 x 350 x 280mm	475 x 325 x 275mm

HOT STAMPING - Container Identification

Your department or company name stamped on containers helps ensure they are returned to you.

Container stamping is available in a range of colours. Stamping is permanent and can't be washed off.

Most containers can be stamped on one or both sides.



All Measurements are Length x Width x Height
Lids to suit the containers are only available in Natural colour unless otherwise specified.



IH006 - Confectionery Tray

NATURAL

Capacity	External Dimensions	Internal Dimensions
29 Litre	712 x 448 x 95mm	680 x 416 x 76mm



IH017 - Heavy Duty Crate

GREY

Capacity	External Dimensions	Internal Dimensions
20 Litre	400 x 280 x 245mm	360 x 245 x 240mm



IH025 - Mesh Base

GREY

Capacity	External Dimensions	Internal Dimensions
25 Litre	580 x 385 x 166mm	518 x 335 x 140mm



IH026 - Stacking

GREY

Capacity	External Dimensions	Internal Dimensions
50 Litre	580 x 385 x 320mm	518 x 335 x 295mm



IH027 - Side Access

GREY

Capacity	External Dimensions	Internal Dimensions
50 Litre	580 x 385 x 320mm	518 x 335 x 295mm



IH073 - Stacking Crate

NATURAL

Capacity	External Dimensions	Internal Dimensions
36 Litre	565 x 387 x 203mm	553 x 355 x 190mm



IH125 - Vented

GREY

Capacity	External Dimensions	Internal Dimensions
12.5 Litre	385 x 290 x 165mm	330 x 235 x 148mm



IH037 - Lug Box

ORANGE

Capacity	External Dimensions	Internal Dimensions
44 Litre	538 x 362 x 334mm	460 x 324 x 253mm



IH098 - Stacking Crate

YELLOW

Capacity	External Dimensions	Internal Dimensions
50 Litre	572 x 382 x 318mm	540 x 350 x 295mm



IH160 - Milk Crate

BLACK

Capacity	External Dimensions	Internal Dimensions
32 Litre	362 x 362 x 325mm	305 x 305 x 310mm



IH300 - Vent Lug Box

ORANGE
BLUE

Capacity	External Dimensions	Internal Dimensions
66 Litre	610 x 419 x 312mm	571 x 381 x 305mm



IH984 - Vented Base

GREY

Capacity	External Dimensions	Internal Dimensions
44 Litre	735 x 535 x 150mm	690 x 485 x 135mm

All Measurements are Length x Width x Height
Lids to suit the containers are only available in Natural colour unless otherwise specified.



IH008 - Commercial Tray

WHITE

Capacity	External Dimensions	Internal Dimensions
N/A	455 x 343 x 32mm	420 x 305 x 25mm



IH009 - Small Tray

WHITE

Capacity	External Dimensions	Internal Dimensions
N/A	456 x 318 x 57mm	422 x 292 x 55mm



**IH310 - Handee Bin
IH312 - Lid**

CLEAR

Capacity	External Dimensions	Internal Dimensions
10 Litre	385 x 300 x 130mm	355 x 270 x 125mm



**IH048 - Nesting Crate
IH158 - Lid**

RED
BLUE
NATURAL

Capacity	External Dimensions	Internal Dimensions
16 Litre	457 x 318 x 165mm	419 x 279 x 152mm



**IH042 - Nesting Crate
IH158 - Lid**

RED
BLUE
NATURAL

Capacity	External Dimensions	Internal Dimensions
27 Litre	457 x 318 x 260mm	419 x 279 x 255mm



IH077 - Liver Tray

NATURAL

Capacity	External Dimensions	Internal Dimensions
11 Litre	514 x 213 x 130mm	483 x 178 x 127mm



**IH059 - Nesting Crate
IH015 - Lid**

ORANGE
NATURAL

Capacity	External Dimensions	Internal Dimensions
22 Litre	527 x 381 x 140mm	489 x 343 x 127mm



**IH089 - Nesting Crate
IH014 - Lid**

ORANGE
BLUE
NATURAL

Capacity	External Dimensions	Internal Dimensions
13 Litre	430 x 323 x 127mm	394 x 285 x 108mm



IH091 - Oven Tub

NATURAL

Capacity	External Dimensions	Internal Dimensions
54 Litre	700 x 600 x 340mm	635 x 535 x 320mm



**IH310 - Handee Bin
IH312 - Lid**

CLEAR

Capacity	External Dimensions	Internal Dimensions
10 Litre	385 x 300 x 130mm	355 x 270 x 125mm



**IH315 - Handee Bin
IH312 - Lid**

CLEAR

Capacity	External Dimensions	Internal Dimensions
15 Litre	385 x 300 x 190mm	355 x 270 x 185mm



IH539R2 - Nesting Tub

NATURAL
BLACK

Capacity	External Dimensions	Internal Dimensions
200 Litre	990 x 660 x 470mm	770 x 440 x 460mm

All Measurements are Length x Width x Height
Lids to suit the containers are only available in Natural colour unless otherwise specified.



IH3026 - Solid Swing Bar Crate

GREY

Capacity	External Dimensions	Internal Dimensions
23 Litre	578 x 386 x 166mm	495 x 327 x 140mm



IH3046 - Vented Swing Bar Crate

GREY

Capacity	External Dimensions	Internal Dimensions
46 Litre	578 x 388 x 280mm	518 x 322 x 253mm



IH3021 - Vented Swing Bar Crate

GREY

Capacity	External Dimensions	Internal Dimensions
26 Litre	578 x 386 x 166mm	495 x 327 x 140mm



NOTE: NOT A STOCK ITEM
Minimum Quantity applies to this product.

IH3138 - Vented Swing Bar Crate

YELLOW

Capacity	External Dimensions	Internal Dimensions
38 Litre	578 x 387 x 240mm	500 x 300 x 212mm

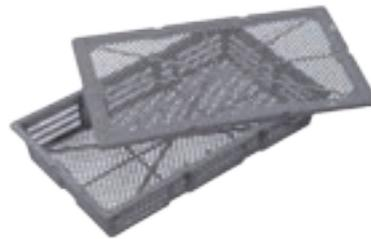

IH001 - Vented Prawn Crate
IH002 - Lid (Grey only)

GREY

Capacity	External Dimensions	Internal Dimensions
15 Litre	600 x 352 x 96mm	565 x 302 89mm



NOTE: NOT A STOCK ITEM
Minimum Quantity of 300 applies to this product.

IH522 - Vented Cape Lug Box

RED

Capacity	External Dimensions	Internal Dimensions
32 Litre	600 x 400 x 200mm	570 x 370 x 193mm



IH3011 - Security with Lid

BLUE

Capacity	External Dimensions	Internal Dimensions
50 Litre	580 x 380 x 325mm	520 x 350 x 295mm



IH3013 - Security with Lid

BLUE

Capacity	External Dimensions	Internal Dimensions
32 Litre	575 x 380 x 200mm	515 x 350 x 185mm



IH012 - Vented Seeding Tray

BLACK

Capacity	External Dimensions	Internal Dimensions
N/A	357 x 357 x 112mm	328 x 328 x 105mm



IH044 - Stack & Nest

RED
NATURAL

Capacity	External Dimensions	Internal Dimensions
20 Litre	584 x 267 x 178mm	533 x 229 x 165mm



TS10PDC - Plastic Dolly - WITH LUGS

Capacity	External Dimensions	Internal Dimensions
26 Litre	640 x 400mm	520 x 360mm



RA670 & RA670L - Plastic Dolly with Integral Handle Hole

Capacity	External Dimensions	Internal Dimensions
300kg	670 x 460 x 145mm	N/A

All Measurements are Length x Width x Height
Lids to suit the containers are only available in Natural colour unless otherwise specified.



N151 - Bucket
N148 - Lid (White only)

RED
WHITE

Capacity	Dimensions - Diameter x Height
13 Litre	300 x 295mm



N258 - Bucket
N073 - Lid (White only)

WHITE

Capacity	Dimensions - Diameter x Height
18 Litre	360 x 295mm



N075 - Bucket
N073 - Lid (White only)

RED
BLUE
WHITE

Capacity	Dimensions - Diameter x Height
22 Litre	360 x 360mm



DOLLY AVAILABLE

IP015 - Circular Bin
IP016 - Lid

RED
NATURAL

Capacity	Dimensions - Diameter x Height
67 Litre	540 x 508mm



DOLLY AVAILABLE

IP018 - Circular Bin
IP016 - Lid

GREEN
NATURAL

Capacity	Dimensions - Diameter x Height
84 Litre	540 x 610mm



IP025 - Circular Bin
IP026 - Lid

RED
NATURAL

Capacity	Dimensions - Diameter x Height
113 Litre	637 x 455mm



IH1210 - Folding Crate

GREY

Capacity	External Dimensions	Internal Dimensions
41 Litre	578 x 385 x 210mm	553 x 357 x 203mm



IH1129 - Folding Crate

GREY

Capacity	External Dimensions	Internal Dimensions
12 Litre	385 x 289 x 129mm	360 x 261 x 122mm



IH1172 - Folding Crate

GREY

Capacity	External Dimensions	Internal Dimensions
33 Litre	578 x 385 x 172mm	553 x 357 x 165mm



IH1094 - Folding Crate

GREY

Capacity	External Dimensions	Internal Dimensions
17 Litre	578 x 385 x 94mm	553 x 357 x 87mm



Folding Crates - When folded, the containers are only 34mm high.

All Measurements are Length x Width x Height
Lids to suit the containers are only available in Natural colour unless otherwise specified.



INJECTION MOULDED LID

CHOOSE YOUR LID AVAILABLE SEPARATELY

POLYURETHANE ECO LID

MS7800 - Mega Bin - Solid MSLIDE - Polyurethane Eco Lid

Designed specifically for the Australian market, the Mega Bin is capable of holding up to half a tonne and has the same footprint dimensions as an Australian pallet. Positive interlocking foot design allows safe stacking up to ten high.

Capacity	External Dimensions	Internal Dimensions
780 Litre	1162 x 1162 x 780mm	1082 x 1082 x 650mm



INJECTION MOULDED LID

CHOOSE YOUR LID AVAILABLE SEPARATELY

POLYURETHANE ECO LID

MS7810 - Mega Bin - Vented MSLIDE - Polyurethane Eco Lid

Designed specifically for the Australian market, the Mega Bin is capable of holding up to half a tonne and has the same footprint dimensions as an Australian pallet. Positive interlocking foot design allows safe stacking up to ten high.

Capacity	External Dimensions	Internal Dimensions
780 Litre	1162 x 1162 x 780mm	1082 x 1082 x 650mm



IH537 - VIPALLET

A cost effective alternative pallet for food processing, pharmaceuticals, groceries, printing, textiles, chemicals, beverages, tanning and general industrial applications.

Static Capacity	Beam Rack Capacity	Dimensions	Weight
4000kg	1000kg	1168 x 1168mm	16.8kg



NS900 - Plastic Pallet

A cost effective alternative pallet for food processing, pharmaceuticals, groceries, printing, textiles, chemicals, beverages, tanning and general industrial applications.

Static Capacity	Beam Rack Capacity	Dimensions	Weight
8000kg	2000kg	1170 x 1170mm	34kg



ECO1160L - VIPALLET

Heavy Duty, 100% Recycled Material.

Static Capacity	Beam Rack Capacity	Dimensions	Weight
10000kg	2000kg	1165 x 1165mm	17.6kg



ECO1165MS - HEAVY DUTY PALLET

Heavy Duty, Smooth Flat Deck Surface with Anti Slip. Available in 100% Recycled or Virgin Material.

Static Capacity	Beam Rack Capacity	Dimensions	Weight
10000kg	2000kg	1165 x 1165mm	24.3kg

Micro Bins

Storage of small components on bench tops and assembly lines

Versatile small parts storage system.

Suitable for a wide range of applications including warehouse, storerooms, hospitals, schools & manufacturing.

**ALL MICRO BINS
NOW AVAILABLE
IN BLACK**

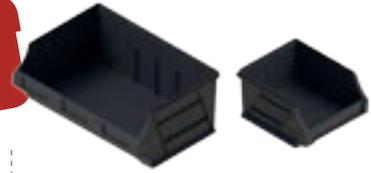

- RED
- GREEN
- BLUE
- YELLOW
- BLACK

IH1000 - Micro Bin

Capacity	Maximum Load	Dimensions
0.5 Litre	2kg	100 x 120 x 60mm



- RED
- GREEN
- BLUE
- YELLOW
- BLACK

IH1001 - Micro Bin

Capacity	Maximum Load	Dimensions
1 Litre	5kg	100 x 178 x 85mm



- RED
- GREEN
- BLUE
- YELLOW
- BLACK

IH1002 - Micro Bin

Capacity	Maximum Load	Dimensions
2.5 Litre	9kg	135 x 225 x 125mm



- RED
- GREEN
- BLUE
- YELLOW
- BLACK

IH1003 - Micro Bin

Capacity	Maximum Load	Dimensions
6 Litre	14kg	205 x 280 x 165mm



- RED
- GREEN
- BLUE
- YELLOW
- BLACK

IH1004 - Micro Bin

Capacity	Maximum Load	Dimensions
12 Litre	18kg	410 x 280 x 165mm



- RED
- GREEN
- BLUE
- YELLOW
- BLACK

IH1006 - Micro Bin

Capacity	Maximum Load	Dimensions
24 Litre	27kg	410 x 440 x 210mm

**GLBMOB
Mobile Parts Trolley**

For storage of small parts that need to be moved to multiple work areas.

Storage Bins - A popular combination of Bin Sizes is 16 Grey; 32 Yellow; 32 Green; 12 Blue; 24 Red, however any combination and quantity are available to be purchased separately.

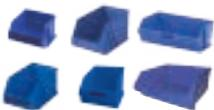

Features	Dimensions
Dimensions	970 x 600 x 1585mm
Handles	2
Castors	2 Fixed & 2 Lockable Swivel



1H082 & 1H083 Plastic Louvre Panels

Optional louvre panels sold separately. Also available in metal.

Model	Construction	Dimensions
1H082	Plastic	153 x 460mm
1H083	Plastic	460 x 460mm

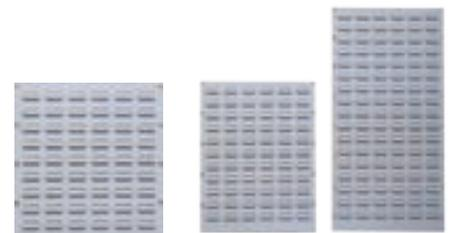

Metal Louvre Panels

Optional louvre panels sold separately. Also available in metal.

Model	Construction	Dimensions
LV455	Metal	455 x 455mm
LV610	Metal	455 x 610mm
LV914	Metal	455 x 914mm

All Measurements are Length x Width x Height. Lids to suit the containers are only available in Natural colour unless otherwise specified.



Visypak Bins

Solid Plastic Body with Clear, Removable Compartments.
Ideal for home & store merchandising.

Model	Compartments	Dimensions
IH040	Clear Removable	103 x 83 x 120mm
IH041	Clear Removable	154 x 126 x 180mm
IH042	Clear Removable	208 x 167 x 235mm



Drawer Organisers

1H050 - 12 Drawer

1H051 - 20 Drawer

Model	Compartments	Dimensions
IH050	6 x 1 & 6 x 2 drawers	230 x 128 x 188mm
IH051	10 x 1 & 10 x 2 drawers	305 x 128 x 230mm



Spare Parts Storage - Extra Long

BLUE
GREY

Model	Dividers	Dimensions
APT27Grey	5	626 x 100 x 100mm
APT27Blue	5	626 x 100 x 100mm



Spare Parts Storage - Extra Large

BLUE
GREY

Model	Dividers	Dimensions
APT28Grey	5	626 x 200 x 100mm
APT28Blue	5	626 x 200 x 100mm



NOTE: TRAYS COME STANDARD WITH TWO DIVIDERS ONLY
Image for illustrative purposes only

IH344 - Small Spare Parts Storage IH301 - Divider

Compartments	Dimensions
Adjustable with Dividers	424 x 105 x 100mm



NOTE: TRAYS COME STANDARD WITH TWO DIVIDERS ONLY
Image for illustrative purposes only

IH335 - Small Spare Parts Storage IH301 - Divider

Compartments	Dimensions
Adjustable with Dividers	324 x 105 x 100mm



IH348 - Small Spare Parts Storage IH302 - Divider

Compartments	Dimensions
Adjustable with Dividers	424 x 203 x 100mm



IH338 - Small Spare Parts Storage IH302 - Divider

Compartments	Dimensions
Adjustable with Dividers	324 x 203 x 100mm

All Measurements are Length x Width x Height. Lids to suit the containers are only available in Natural colour unless otherwise specified.



RL165 - Tank

Capacity	Dimensions
165 Litre	610 x 610 x 465mm



**RL250 - Tank
RL250L - Lid**

Capacity	Dimensions
250 Litre	1030 x 510 x 495mm



**R340/610 - Tank
R340/610L - Lid**

Capacity	Dimensions
340 Litre	990 x 695 x 660mm



**R340/915 - Tank
R340/915L - Lid**

Capacity	Dimensions
340 Litre	690 x 690 x 955mm



**RL455 - Tank
RL455L - Lid**

Capacity	Dimensions
455 Litre	1230 x 620 x 600mm



**RL690 - Tank
RL455L - Lid**

Capacity	Dimensions
690 Litre	1230 x 620 x 930mm



RM18TR - Bin
INCLUDES LID &
4 SWIVEL CASTORS.
Also Available without Castors.



Capacity	Dimensions
90 Litre	640 x 320 x 730mm



RM19TR - Bin
INCLUDES LID &
4 SWIVEL CASTORS.
Also Available without Castors.



Capacity	Dimensions
85 Litre	460 x 410 x 670mm



Trays

Model	Capacity	Dimensions
RL50	50 Litre	800 x 550 x 120mm
RL95	95 Litre	1050 x 800 x 120mm
RL120	120 Litre	1160 x 540 x 200mm



TS10PD - Plastic Dolly

Compatible with IH060, IH051, IH078, IH02260, IH02520, IH02780, IH317 & IH3011



Capacity	Dimensions
150kg	620 x 400mm



**IP015 - Tub
IP018 - Tub
IP016 - Lid**

NOTE: Dolly sold separately

Model	Dimensions - Diameter x Height
IP015	540 x 508mm
IP018	540 x 610mm



TS01518 - Dolly

Model	Dimensions - Diameter x Height
TS01518	540 x 610mm

All Measurements are Length x Width x Height
Lids to suit the containers are only available in Natural colour unless otherwise specified.

All tanks are moulded from industrial food grade LDPE resin and have a high resistance to impact and chemical attack. They are stabilised against ultra-violet radiation and will withstand direct sunlight for many years. Operating temperatures range from -40°C to more than 60°C. Standard tank colours are natural and black, other colours are available on request. BSP threaded fittings and flanges used for tank outlets and valves are available for all tanks.

Circular Tanks - CS Series



CSL40 - Drum
CSL40L - Lid

NATURAL
BLACK



CS45 - Drum
CS45L - Lid
CS45H - Handle

BLUE
NATURAL
BLACK



CS90 - Drum & Lid

NATURAL
BLACK

Capacity	Dimensions - Diameter x Height
40 Litre	430 x 460mm

Capacity	Dimensions - Diameter x Height
45 Litre	445 x 500mm

Capacity	Dimensions - Diameter x Height
90 Litre	500 x 700mm



CSL115 - Drum
CSL115L - Lid

NATURAL
BLACK



CS150 - Drum
CS150L - Lid

NATURAL
BLACK



CSL215 - Drum
CSL215L - Lid
(White only)

NATURAL
BLACK

Capacity	Dimensions - Diameter x Height
115 Litre	540 x 710mm

Capacity	Dimensions - Diameter x Height
150 Litre	585 x 870mm

Capacity	Dimensions - Diameter x Height
215 Litre	630 x 920mm



CR110 - Drum
INCLUDES LID.

NATURAL
BLACK



CR200 - Drum
INCLUDES LID.

NATURAL
BLACK



CR330 - Drum
INCLUDES LID.

NATURAL
BLACK

Capacity	Dimensions - Diameter x Height
110 Litre	500 x 830mm

Capacity	Dimensions - Diameter x Height
200 Litre	590 x 980mm

Capacity	Dimensions - Diameter x Height
330 Litre	665 x 1240mm

Rectangular & Square Tanks - R Series

The R Series Tanks are both square & rectangular. Rectangular tanks are popular for order picking, brine tanks, boning & dry ingredient storage.



R100 - Tank
R100L - Lid

NATURAL
BLACK



R140 - Tank

NATURAL
BLACK



R160 - Tank
R160L - Lid

NATURAL
BLACK

Capacity	Dimensions
100 Litre	780 x 525 x 360mm

Capacity	Dimensions
140 Litre	670 x 440 x 495mm

Capacity	Dimensions
160 Litre	690 x 690 x 490mm

All Measurements are Length x Width x Height
Lids to suit the containers are only available in Natural colour unless otherwise specified.



MGB80 - 80 Litre Wheelie Bin



MGB120 - 120 Litre Wheelie Bin



MGB240 - 240 Litre Wheelie Bin



2 Tier Longspan Workbench - Standard

Features	Specifications				
Bench Length	1000mm	1500mm	1800mm	2000mm	2400mm
Bench External Length	1120mm	1620mm	1920mm	2120mm	2520mm
Bench Height	1000mm				
Bench Depth	460, 605 & 910mm				



4 Tier Longspan Workbench - Standard

Features	Specifications				
Bench Length	1000mm	1500mm	1800mm	2000mm	2400mm
Bench External Length	1120mm	1620mm	1920mm	2120mm	2520mm
Bench Height	1000mm				
Overall Height	2000mm				
Bench Depth	910mm with 460mm Top Shelves				



GLBMOB - Mobile Parts Trolley

Features	GLBMOB
Dimensions	1585H x 970W x 600D mm
Handles	2
Fixed Castors	2
Swivel Castors	2 Lockable
Bin Quantity (Sold Separately)	A popular combination of Bin Sizes is 16 Grey; 32 Yellow; 32 Green; 12 Blue; 24 Red. However you can purchase as many or as little as needed of each type.

COOL ROOM SHELVING



Shelving - 5 Shelf Post Style with ABS REAL TUFF Shelves

ABS Real Tuff Removable Shelves.
Welded 32mm x 2.5mm Roll Formed Section Frames.
Available Shelf lengths from 600mm to 1800mm in increments of 150mm.
Width can be 300, 450, 525 or 600mm deep.
Finishes available are Zinc Lacquered, Polished Stainless Steel, Hot Dip Galvanised or Powder Coated.



Shelving - 5 Shelf Post Style with Wire Grid

Strong Wire Shelves give allow maximum airflow.
Welded 32mm x 2.5mm Roll Formed Section Frames with Wire Grid of 4mm.
Available Shelf lengths from 600mm to 1800mm in increments of 150mm.
Width can be 300, 375, 450, 525 or 600mm deep.
Finishes available are Zinc Lacquered, Polished Stainless Steel & Powder Coated.

STEEL UNI-SHELVING



UNI-Shelving - 7 Shelf

75kg Shelf Capacity.
Quality Colourbond® Bluescope® Steel.
25mm Shelf Increments.
100% Australian Made.
10 Year Warranty.
NOTE: Storage Bins Not Included.

Model	Specifications
UNIS900/300	2175 x 900 x 300mm
UNIS900/400	2175 x 900 x 400mm
UNIS1200/300	2175 x 1200 x 300mm
UNIS1200/400	2175 x 1200 x 400mm
ADDITIONAL SHELVES Available separately	
EXS900/300	Extra Shelf inc. Shelf Clip - 900 x 300mm
EXS900/400	Extra Shelf inc. Shelf Clip - 900 x 400mm
EXS1200/300	Extra Shelf inc. Shelf Clip - 1200 x 300mm
EXS1200/400	Extra Shelf inc. Shelf Clip - 1200 x 400mm
SCLIP	Shelf Clip

**CUSTOM SIZES
AVAILABLE**

STANDARD
COLOURS
WS SG

Longspan shelving is ideal for box storage, archive shelving, retail displays, spare parts, storerooms, sea containers, warehouses, workshops, workbenches and any other industrial, commercial or domestic use.



1800mm Longspan - 4 Shelf

Chipboard/Metal or Mesh Shelves.
Gun Metal Grey Powder Coated Finish.
Corporate Colours available on request.

Features	Specifications
Dimensions	2000H x 1800W x 460D mm
External Bay Length	1920mm
Shelf Loading	400kg

Longspan Shelving is very easy to assemble and is a quick and economical way to transform your storage area. Our frames come pre-assembled to make assembly quick and simple.



1800mm Longspan - 5 Shelf

Chipboard/Metal or Mesh Shelves.
Gun Metal Grey Powder Coated Finish.
Corporate Colours available on request.

Features	Specifications
Dimensions	2000H x 1800W x 460D mm
External Bay Length	1920mm
Shelf Loading	400kg



2000mm Longspan - 4 Shelf

Chipboard/Metal or Mesh Shelves.
Gun Metal Grey Powder Coated Finish.
Corporate Colours available on request.

Features	Specifications
Dimensions	2000H x 2000W x 460D mm
External Bay Length	2120mm
Shelf Loading	350kg



2000mm Longspan - 5 Shelf

Chipboard/Metal or Mesh Shelves.
Gun Metal Grey Powder Coated Finish.
Corporate Colours available on request.

Features	Specifications
Dimensions	2000H x 2000W x 460D mm
External Bay Length	2120mm
Shelf Loading	350kg



2400mm Longspan - 4 Shelf

Chipboard/Metal or Mesh Shelves.
Gun Metal Grey Powder Coated Finish.
Corporate Colours available on request.

Features	Specifications
Dimensions	2000H x 2400W x 460D mm
External Bay Length	2520mm
Shelf Loading	250kg



2400mm Longspan - 5 Shelf

Chipboard/Metal or Mesh Shelves.
Gun Metal Grey Powder Coated Finish.
Corporate Colours available on request.

Features	Specifications
Dimensions	2000H x 2400W x 460D mm
External Bay Length	2520mm
Shelf Loading	250kg



BEAM CONNECTORS



SHELF OPTIONS



Chipboard



Meshdeck



Galvanised Metal



Features	Specifications
Heights	2000mm, 2400mm, 3000mm
Depths	460mm, 605mm, 900mm
Beam Length	1000mm, 1500mm, 1800mm, 2000mm, 2400mm
Load Capacity	900kg, 550kg, 400kg, 350kg, 250kg
Finish	Powder Coated Grey

LOCKERS

PW1830/914 Personal Wardrobe

Personal Hang Rail & Mirror.
 Quality Powdercoated Finish.
 Flush mounted doors with 180 degree opening capacity.
 Quality Steel with reinforced doors.
 3 Point Locking Mechanism.
 10 Year Warranty.

STANDARD COLOURS
 GR SG



Features	Specifications
Dimensions	1830H x 914W x 463D mm
Door	Full Length Double Doors
Lock	3 Point Mechanism with Key

Lockers

Available in 2 widths - 305mm & 380mm.
 Quality Powdercoated Finish.
 Flush mounted doors with 180 degree opening capacity.
 Card Holder Provision for easy identification.
 Pad Latch and Key Lock options available.
 10 Year Warranty.

STANDARD COLOURS
 SG



LK2COMBO



Model	Specifications (Height x Width x Depth)
LK1T305	1 Door - 1830 x 305 x 460mm
LK1T380	1 Door - 1830 x 380 x 460mm
LK2T305	2 Door - 1830 x 305 x 460mm
LK2T380	2 Door - 1830 x 380 x 460mm
LK2COMBO	2 Door - 1830 x 380 x 460mm
LK3T305	3 Door - 1830 x 305 x 460mm
LK3T380	3 Door - 1830 x 380 x 460mm
LK4T305	4 Door - 1830 x 305 x 460mm
LK4T380	4 Door - 1830 x 380 x 460mm
LK6T305	6 Door - 1830 x 305 x 460mm
LK6T380	6 Door - 1830 x 380 x 460mm
LK8T305	8 Door - 1830 x 305 x 460mm

CUSTOM DESIGN & MANUFACTURE



Team Systems can manufacture to suit your individual requirements.

Our new, large manufacturing workshop at our Victorian Head Office in Dandenong South can cater to any custom made or specialised project your business requires.

With most of our manufacturing employees working in our business for 5, 10 or more years, there is a great deal of pride in the quality and workmanship of our products.

We are proud of our award winning designs throughout our local and national distribution system.

All cutting, tube bending, punching, welding and assembly work is completed in-house under strict quality control procedures.

We also have the ability to customise your designs on medium and large size orders to suit your needs.

- SERVICE STATION DISPLAYS
- LAUNDRY & NURSERY TROLLEYS
- SPECIALISED STOCK PICKERS
- MEDICAL & EDUCATIONAL
- CATERING TROLLEYS

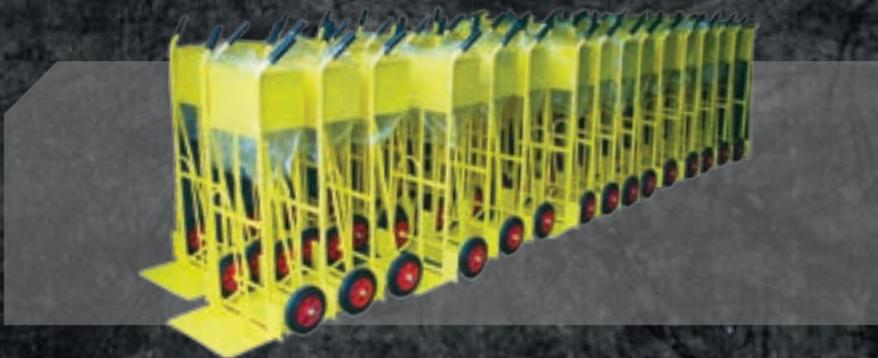

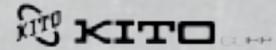
VICTORIA**DANDENONG - HEAD OFFICE**

Team Systems Material Handling
121 Logis Boulevard
Dandenong South VIC 3175
t 03 8791 5777 f 03 8791 5799
melbourne@teamsystems.net.au

**CAMPBELLFIELD
WAREHOUSE**

Team Systems Material Handling
7/33 Lara Way
Campbellfield VIC 3061
t 03 9357 0500 f 03 9357 5105
cfield@teamsystems.net.au

**NEW SOUTH WALES
WETHERILL PARK****SHOWROOM/WAREHOUSE**

Team Systems Material Handling
8 Durian Place
Wetherill Park NSW 2164
t 02 9609 7782 f 02 9609 6953
sydney@teamsystems.net.au

**WESTERN AUSTRALIA
CANNING VALE****SHOWROOM/WAREHOUSE**

Ideal Systems Material Handling
211 Bannister Road
Canning Vale WA 6155
t 08 9455 4855 f 08 9455 4899
perth@idealsystems.com.au

**QUEENSLAND****YATALA - SHOWROOM/WAREHOUSE**

Team Systems Material Handling
Unit 11 28 Burnside Road
Yatala QLD 4207
t 07 3807 9144 f 07 3807 9155
brisbane@teamsystems.net.au

